

# RV GENERATOR HANDBOOK

100 YEARS OF POWER GENERATION



# CONTENTS

<b>INTRODUCTION</b>	<b>2</b>
100 years of power generation	3
<b>1 IMPORTANT SAFETY PRECAUTIONS</b>	<b>4</b>
<b>2 QUICKSTART GUIDE FOR RV GENERATOR OWNERS</b>	<b>6</b>
Cummins websites	7
Nameplate / description	8
Nameplate / location	9
<b>3 RV GENERATOR OPERATION</b>	<b>10</b>
Starting and stopping procedures	10
Automatic generator starting devices	11
Breaking in your new generator	11
Exercising your generator	11
Understanding power: amps, volts and watts	12
30-amp vs. 50-amp shore power	13
Load management basics	14
Determining your generator's power capability	14
Operating motor-driven appliances	16
Air conditioner "short-cycling"	16
Effects of high altitude and extreme temperatures	16
Managing electrical loads	17
Preventing generator surging	18
Tips to help prevent surging	19
Installed Cummins generators are exceptionally quiet	20
<b>4 FREQUENTLY ASKED QUESTIONS (FAQs)</b>	<b>21</b>
<b>5 GENERATOR CARE AND MAINTENANCE</b>	<b>27</b>
Dos and don'ts for better generator performance	30
Keep your generator clean and inspect it regularly for damage	31
Troubleshooting guide	36
Fault codes	38

RV QD 3200 control panel maintenance messages . . . . .	39
Service diagrams . . . . .	40
<b>6 GENERATOR MAINTENANCE: PARTS AND CHEMICALS . . . . .</b>	<b>48</b>
Insist on the quality of green label parts . . . . .	48
Use Cummins oil and service / maintenance chemicals to ensure performance . . . . .	50
<b>7 WARRANTY AND SERVICE . . . . .</b>	<b>56</b>
Auto generator start control system . . . . .	57
<b>8 CURRENT RV GENERATOR MODEL INFORMATION . . . . .</b>	<b>58</b>
Quiet Gas . . . . .	60
Quiet Diesel. . . . .	62
Portable. . . . .	64

OFFICIAL HANDBOOK  
FOR THE WORLD'S QUIETEST  
RV GENERATORS.

Cummins **Onan**  
RV Generator Handbook

Performance you rely on.<sup>®</sup>



## INTRODUCTION

Thank you for your interest in Cummins RV generators.

We strive to provide the quiet, reliable auxiliary power you need to make your life on the road all it can be. Cummins generators are engineered for years of trouble-free service, and our nationwide service network is the largest in the industry.

Cummins generators come in a wide variety of sizes and fuel types. From smaller gasoline and propane models to larger diesel-powered models for bus-type Class A RVs, there's a model for whatever type of RVing you're interested in.

This RV Generator Handbook contains basic information that will allow you to use and maintain your new generator. Included here are helpful tips for operation along with maintenance, parts and service information. This handbook is a general supplement to the more specific information contained in the operator manual that comes with every new Cummins generator.

Our promise to you is to continue to provide the best-performing RV generators and the largest, best-trained service organization in the business. By following the tips contained here and having your Cummins authorized parts and service distributor or dealer provide service at recommended intervals, your generator will provide reliable, easy-to-own performance for years to come.

# 100 YEARS OF POWER GENERATION

**1919**

Cummins is founded by Clessie Cummins in Columbus, Indiana. D.W. Onan & Sons was founded by D.W. Onan in Minneapolis, Minnesota (USA)

**1920**

Onan Inc. was founded by D.W. Onan

**1926**

Ten Lite First Onan generator produced by D.W. Onan & Sons

**1967**

CCK Introduction: First dedicated fixed mount generator installed in an RV

**1986**

Cummins acquired Onan Corporation  
Last genset product off the Fridley Line

**1996**

Introduction of first variable speed inverter-based generator

**2000**

Introduction of first electronic fuel-injected RV generator

**2005**

Introduction of first hybrid-based RV generator set

**2010**

Two million generators produced

**2020**

100 years of power generation



David Onan and his Wrist Meter





# 1 | IMPORTANT SAFETY PRECAUTIONS

Please read your generator operator's manual carefully so you understand all the precautions for safe, efficient operation. Most accidents occur from failing to follow fundamental safety rules. In general:

- Never operate or occupy your RV unless equipped with a properly functioning carbon monoxide detector. Be sure to check the expiration date on your detector.
- Exhaust gas is deadly. Check all exhaust system connections regularly for leaks and tighten them as necessary. **DO NOT** operate the generator with a faulty exhaust system.
- If your RV bottoms out on a driveway or road object, inspect the generator exhaust system for damage. The tail pipe must extend past the edge of the vehicle.
- Always operate the generator in an area where the wind will carry away the exhaust fumes.
- Don't store anything, especially gas, oil, rags or other flammable materials, in the generator compartment.
- Keep the exhaust and air intake free from obstructions such as clothing, furniture or other material, like road debris.
- Perform all service and maintenance work with the generator engine off and the negative battery cable disconnected. Moving parts can cause severe personal injury or death, and live wires could cause fatal electrocution.

- Backfeed to utility systems can create serious risks to life or property. Do not connect the generator to a building electrical system except through an approved transfer device and after the building's main breaker is opened.
- Autostart caution: Be sure to deactivate your autostart system before storing your RV, conducting electrical maintenance or handing over your RV to a service center. To be sure your generator won't start while conducting maintenance, follow the operator's manual and disconnect the remote electrical harness prior to any service.

## STATEMENT REGARDING EXHAUST EXTENSIONS

While we understand that some organizations require the use of exhaust extensions, Cummins does not endorse the use of RV generator exhaust pipe extensions. Like all fuel-burning devices, engine-driven generators emit carbon monoxide (CO) which, if not safely handled, can produce serious injury or death. Cummins generators, in conjunction with RV OEM-installed tail pipes, are designed to meet RVIA standards for safely handling exhaust gases while minimizing noise and maximizing generator performance. Improper modifications to the exhaust components can result in unexpected hazards to the vehicle occupants.

Cummins concerns revolve around six areas:

1. **Weight:** Unless entirely self-supporting, extensions add weight to the end of the generator tail pipe, which can stress, crack or break the exhaust system parts that are not designed to carry the additional weight. This could result in exhaust gases escaping directly under the coach and therefore could be extremely dangerous to vehicle occupants.
2. **Fit:** To be effective conveyors of exhaust, connections and joints must be gastight. Such connections are not guaranteed unless the exhaust extension kit is properly assembled each time it is used.
3. **Exhaust direction:** Because exhaust extensions vent at the roof line, there is a major concern that exhaust will be sucked in by rooftop air conditioners, vents and windows.
4. **Heat:** Many extension designs involve exposed metal that can be a burn hazard to anyone passing by who might contact the exposed extension pipe.
5. **Back pressure:** Adding an extension may increase back pressure on the engine and thereby reduce engine performance or cause the engine to fail to meet government-regulated exhaust standards.
6. **Warranty:** The use of an exhaust extension kit may void the Cummins warranty.



## 2 | QUICKSTART GUIDE FOR RV GENERATOR OWNERS

There are some basic things that an owner needs to know about his or her Cummins RV generator. First of all, become familiar with the basic safety rules covered on the previous pages. Next, an understanding of the following key topics will help you get the most trouble-free, cost-effective auxiliary power while you're experiencing all that the RV lifestyle has to offer.

- **Starting and stopping procedures** - It's very important to understand the correct way to turn your generator on and off. See pages 10 and 11 for an in-depth explanation of this basic generator function.
- **Breaking in your new generator** - Following the recommended procedure for the initial running period can be beneficial for added service life. See page 11 to learn more about how to manage this important aspect of your generator.
- **Exercising your generator** - It's also very important to exercise your generator regularly, to keep everything in good working order and (in the case of gasoline sets) to avoid fuel varnishing, which can affect performance if the generator is stored for an extended time. See page 11 for more information about this important topic.
- **Managing loads and understanding battery charging** - See pages 17 and 18 for an explanation of why these are important as well.



# CUMMINS WEBSITES

[Rv.cummins.com](http://Rv.cummins.com) is the official online home for all Cummins products. Visit our site to learn more about our full line of RV generators for motorhomes and trailers.

You can find the dealer nearest you with our sales and service locator. Check it out today at [cummins.com/sales-and-service](http://cummins.com/sales-and-service).

Green Label Parts are available at most Cummins dealer or regional service locations. If parts are not available locally or if it is more convenient, you can shop online at the factory store: [shopcummins.com](http://shopcummins.com) and [shopcummins.ca](http://shopcummins.ca).

Maintenance parts and manuals are available for most RV generator models and include the following:

- Oil filters
- Oil filter wrench
- Air filters
- Fuel filters
- Spark plugs
- Plug wires
- Glow plugs
- Maintenance kits
- Line voltage monitor
- Manuals - Operator, Parts, Installation and Service



To experience our world-class service and support, visit [care.cummins.com](http://care.cummins.com), and to locate a dealer, visit: [cummins.com/engines/motorhome-and-rv/find-motorhome-and-rv-service-location](http://cummins.com/engines/motorhome-and-rv/find-motorhome-and-rv-service-location).

# NAMEPLATE / DESCRIPTION

Each Cummins generator has a model/spec number description, which is shown on the serial number tag attached to the generator. Here is a representation of the tag on an Onan RV QG 4000.

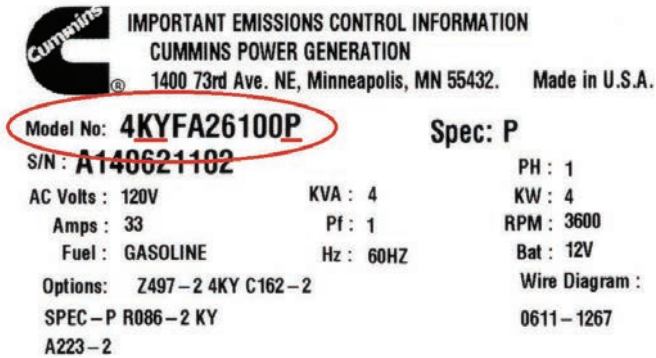

Note the highlighted letter code, in this case P, which denotes the specification type of the particular generator, which can then be referred to as spec P. This information is helpful in determining which parts to use if service is needed at some point in the future. Note your new Cummins model identifier and spec code in the boxes below. Then if you need to obtain service parts in the future, you'll have an easily accessible record to speed up the process.

## MODEL / SERIAL NUMBER RECORD

When contacting a Cummins authorized RV service and parts dealer for service, maintenance or parts questions, always refer to the complete model, spec and serial number of your Cummins RV generator. These numbers are printed on your Cummins generator unit nameplate. Write them below for easy reference.

Model No:

Serial No:

## PHOTOGRAPH YOUR NAMEPLATE

Anytime you contact Cummins or your dealer for service, parts or questions about your generator, it is important to have your nameplate information handy. One way to do this is to take a photograph of your generator's nameplate and store it on your phone. The next page shows you where to find the nameplate on your generator.

# NAMEPLATE / LOCATION

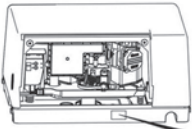

RVQG - 5500 - 7000

**IMPORTANT ENGINE INFORMATION**  
**CUMMINS POWER GENERATION**  
 1400 73rd Ave. NE  
 Minneapolis, MN 55432  
 Made in U.S.A.

Model No: [REDACTED]  
 S/N: [REDACTED] P/N: [REDACTED]  
 AC Volts: kVA: kW:  
 Amps: Pf: RPM:  
 Fuel: Hz: Bet:  
 Options: Wiring Diagram

Insulation - NEMA Class F Ambient 40°C

[The engine family designation, engine displacement, statement of compliance with the applicable EPA and / or California emissions regulations, including the compliance period or category, appear in this block on the actual nameplate on the genset.]



**IMPORTANT ENGINE INFORMATION**  
**CUMMINS POWER GENERATION**  
 1400 73rd Ave. NE  
 Minneapolis, MN 55432  
 Made in U.S.A.

Model No: [REDACTED]  
 S/N: [REDACTED] P/N: [REDACTED]  
 AC Volts: kVA: kW:  
 Amps: Pf: RPM:  
 Fuel: Hz: Bet:  
 Options: Wiring Diagram

Insulation - NEMA Class Ambient

RVQG - 3600 - 4000

**Cummins Onan**

3.3WEEK-93384 656P00001

MODEL No.	SPEC LETTER	SERIAL
3.3WEEK-93384		656P00001

3.3kw 3110RPM Cummins Power Generation  
 120 V AC Diesel 1400 73rd Ave NE  
 25.7 Amps 50 V Hz Minneapolis, MN 55432  
 Single Phase 63kg(135 lb) Made in Italy 60Hz  
 Class III, 40°C 60Hz

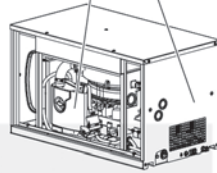

RVQD - 3200

**IMPORTANT ENGINE INFORMATION**  
**CUMMINS POWER GENERATION**  
 1400 73rd Ave. NE  
 Minneapolis, MN 55432  
 Made in U.S.A.

Model No: [REDACTED]  
 S/N: [REDACTED] P/N: [REDACTED]  
 AC Volts: kVA: kW:  
 Amps: Pf: RPM:  
 Fuel: Hz: Bet:  
 Options: Wiring Diagram

Insulation - NEMA Class F Ambient 40°C

THIS ENGINE MEETS 1996-1999 CALIFORNIA EMISSION REGULATIONS FOR ULGE ENGINES

SKB719U6D2RA 719 cc

REFER TO OPERATOR'S MANUAL FOR MAINTENANCE SPECIFICATIONS AND ADJUSTMENTS. 99-2496 URC

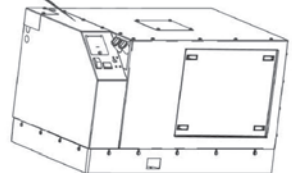

RVQD 6000 - 8000

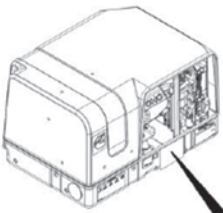

**IMPORTANT ENGINE INFORMATION**  
**CUMMINS POWER GENERATION**  
 1400 73rd Ave. NE  
 Minneapolis, MN 55432  
 Made in U.S.A.

Model No: [REDACTED]  
 S/N: [REDACTED] P/N: [REDACTED]  
 AC Volts: kVA: kW:  
 Amps: Pf: RPM:  
 Fuel: Hz: Bet:  
 Options: Wiring Diagram

Insulation - NEMA Class Ambient

REFER TO OPERATOR'S MANUAL FOR MAINTENANCE SPECIFICATIONS AND ADJUSTMENTS

99-2495

RVQG - 2500 - 2800

**IMPORTANT ENGINE INFORMATION**  
**CUMMINS POWER GENERATION**  
 1400 73rd Ave. NE  
 Minneapolis, MN 55432  
 Made in U.S.A.

Model No: [REDACTED]  
 S/N: [REDACTED] P/N: [REDACTED]  
 AC Volts: kVA: kW:  
 Amps: Pf: RPM:  
 Fuel: Hz: Bet:  
 Options: Wiring Diagram

Insulation - NEMA Class Ambient

[The engine family designation, engine displacement, statement of compliance with applicable EPA and / or California emissions regulations appear in this block on the actual nameplate on the genset.]

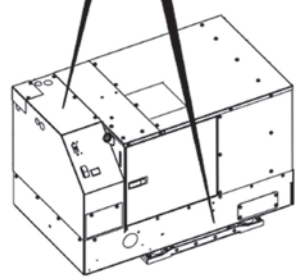

RVQD - 10000 - 12500

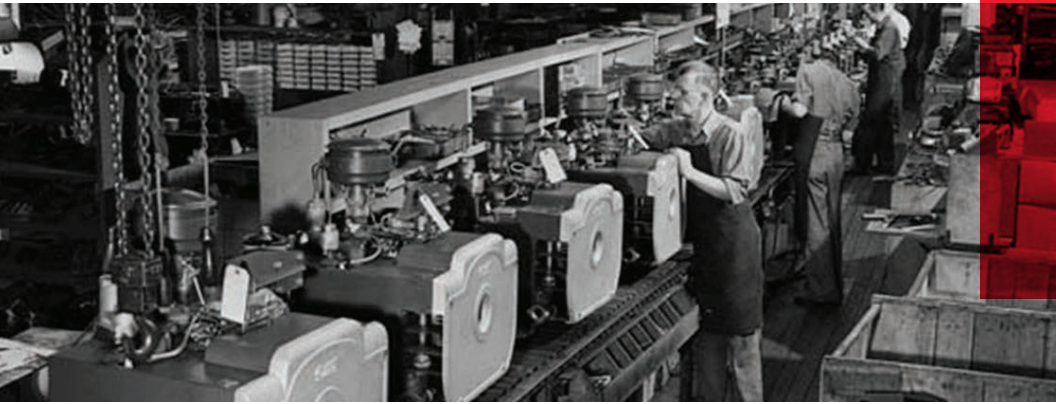

## 3 | RV GENERATOR OPERATION

### STARTING AND STOPPING PROCEDURES

Your Cummins generator can be started (except RV QD 3200) and stopped from the integral control panel on the generator or from the optional remote control panel inside the vehicle if your RV is so equipped.

It is a good practice, before starting the generator, to turn off air conditioners and large electrical loads. If the unit has not been started in the last several hours, prime by holding the stop button on the remote start panel or the control on the generator itself.

*NOTE: Prime is available for all current production models, excluding legacy products. If you have an automatic generator start system, the delay is built into the automatic transfer switch.*

#### To start:

- Press and hold START at the interior control panel or outside at the set.
- Quiet Diesel: When you press START, the control verifies several parameters, including temperature. Glow plug burn and fuel pump prime happen prior to the starter engaging. On a cold morning, this 'prime' could take up to 30 seconds before you hear the starter engage. (This is normal.)
- Don't over-crank with no start-crank no longer than 20 seconds; allow the starter to cool for at least two minutes between attempts.
- Allow generator to run for 30 seconds prior to applying large loads. In many cases, the RV's automatic transfer switch has this delay built in.

**To stop:** Press the STOP button at the control panel or at the set.

It is a good practice to turn off air conditioners and large electrical loads and allow the generator to run for three to five minutes prior to stopping. This allows the generator to cool down.

## **AUTOMATIC GENERATOR STARTING DEVICES**

Many modern RVs are equipped with a panel or device which automatically starts the generator based on low battery voltage, interior RV temperature or loss of shore power. These devices' operations vary depending on the manufacturer. In some cases, the autostart gen device may trigger a start or stop command without removing load. For these cases, this operation is normal and will not harm your generator. Auto gen/start panels are discussed later in this manual. Several manufacturers besides Cummins offer auto gen start systems. Please check with your manufacturer (or OEM) for their exact operating terms.

## **BREAKING IN YOUR NEW GENERATOR**

Your generator will perform better if you follow the break-in procedure recommended in the operator's manual. The break-in process typically involves running the generator at about 50 percent load for two hours, then at about 75 percent load for two hours, then letting it cool down. Refer to the maintenance chart on page 29 for maintenance intervals. A break-in procedure will decrease oil consumption and improve power characteristics.

## **EXERCISING YOUR GENERATOR**

It may seem surprising that “not” using your generator could cause performance problems, but with RV generators that's exactly the case. Regular “exercise” is a very important part of keeping your generator healthy. Lack of exercise can cause moisture build-up and fuel system degradation that will make it run poorly. In fact, in as little as 30 days, the fuel in gasoline-powered generators can begin to gum and varnish the fuel system. Fuel varnishing results in hard starting and surging. (A surging generator never settles at a stable operating speed.)

To prevent such problems, it is recommended to run gasoline generators at a minimum of 50 percent capacity (2,000 watts, or one air conditioner for a 4,000-watt set) for two hours once every month. This is necessary to help keep moving parts lubricated, expel moisture and control fuel varnishing in the carburetor. A long two-hour exercise period is preferable to several short periods. While traveling, this can be accomplished by running the air conditioning. If you own an LP or diesel generator, regular exercising can help reduce internal condensation and helps keep seals lubricated. Remember to exercise, not just start and run your generator.

# UNDERSTANDING POWER: AMPS, VOLTS AND WATTS

Electrical power is represented by volts, amps and watts. Understanding how much power you need or have available to use in your RV is important; what follows is how these terms interact with each other.

- **Amps**-is a representation of the amount of current flowing in a wire or conductor. While the shore power receptacle and breaker, along with the generator, determine the maximum power potential, the size of the wires and internal breakers really determines the RV's 'amp' capacity for any individual circuit and as a whole.
- **Volts**-is a representation of the amount of electrical potential present. Typically for an RV, this is 120 VAC or 120/240 VAC when running from shore power, generator or onboard inverter. When operating from batteries, the voltage is 12 VDC. The propulsion engine alternator produces 12 VDC to charge the batteries. Likewise, battery chargers charge/maintain the batteries while plugged into shore power or a generator. Many interior lights, absorption refrigerators, LP furnaces, etc., operate on 12 VDC. Modern inverters take 12 VDC and convert it to 120 or 240 AC to operate appliances when shore power or a generator is not present.
- **Watts**-is the true, "apples to apples" representation of power. It is simply calculated by multiplying voltage x amps = watts.

## *FOR EXAMPLE:*

A hair dryer plugged into a 120 V outlet that uses 10 amps of power would require  $10 \text{ amps} \times 120 \text{ Volts} = 1,200 \text{ watts}$ , or 1.2 kilowatts (kW) of power.

# 30-AMP VS. 50-AMP SHORE POWER

Most modern RVs are wired for 30- or 50-amp shore power. An important distinction with these two options is rated voltage.

- A 30-amp shore cord is rated at 120 V. Therefore, the max total power available is 3,600 watts.
- A 50-amp shore cord is rated at 240 V. The total max power available here is 12,000 watts.

This means that a typical 50-amp shore cord has close to three times greater the amount of potential power than a 30-amp shore cord. The actual power the RV will have available to use will depend on its individual breaker size, configuration and wire size designed by the manufacturer.

- An RV generator capable of matching the potential power of a 50-amp shore cord plugged into a 240 V receptacle would have to be rated at 12,000 watts, or 12 kW.
- An RV generator capable of matching the potential power of a 30-amp shore cord plugged into a 120 V receptacle would need to be rated for 3,600 watts, or 3.6 kW, at a minimum.



---

**30-Amp RV Receptacle (120 V) –  
3,600 Watts**



---

**50-Amp RV Receptacle (240 V) –  
12,000 Watts**

# LOAD MANAGEMENT BASICS

In order to get the most out of your Cummins generator, you need to understand how it interacts with the electric system of your RV. At a very high level, your generator is connected via the circuit breaker panel to a wide variety of loads. Two of the most important loads that will impact the performance of your generator are the air conditioner(s) and the converter or battery charger.

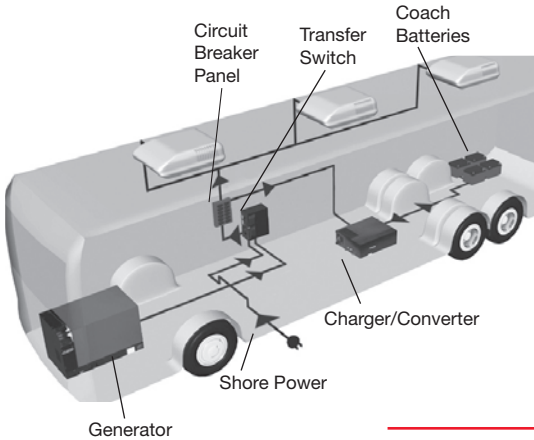

---

To understand how battery chargers, automatic generator start systems and other baseloads affect your generator, you need to be aware of three things:

- Your generator's power capability
- How to manage electrical loads
- Battery charging times

## DETERMINING YOUR GENERATOR'S POWER CAPABILITY

To determine what your generator can power, use the chart below to estimate the total combined watts of all the appliances, lamps, battery chargers, air conditioners and other electrical products you typically use at the same time. (All electrical appliances and lights are labeled with their power requirements expressed in watts or amps.) You can use any number of appliances simultaneously, as long as their combined wattage doesn't exceed the electrical output of your Cummins generator or your RV's circuit breaker rating.



## COMMON POWER REQUIREMENTS

APPLIANCE	AVERAGE REQUIRED WATTAGE	AMPS
AIR COMPRESSOR (1 HP)	900-1800	7.5-15
AIR CONDITIONER	1200-2400	10-20
BATTERY CHARGER	Up to 3000	6-28
BLENDER	450-700	3.3-5.8
BROILER	1400-1700	11.6-14
BROOM / VACUUM	1000-1440	8.3-12
ENTERTAINMENT SYSTEM	85	0.7
COFFEE POT	900-1200	7.5-10
CONVERTER	500-1000	4-8
CURLING IRON	20-50	0.16-0.41
DISHWASHER	1200-2400	10-20
DRILL	250-1000	2-8
ELECTRIC BLANKET	60-100	0.5-0.8
FAN	10-175	0.08-1.45
FLAT IRON	40-80	0.3-0.6
FRYING PAN / WOK	1000-1500	8-12.5
GAME CONSOLE	19-200	0.16-1.6
HAIR DRYER	1200-1875	10-15.6
IRON	1000-1800	8-15
LAPTOP	20-50	0.16-0.41
LIGHT BULBS	13-100	0.1-0.8
MICROWAVE	750-1500	6.25-12.5
RADIO	50-200	0.4-1.6
REFRIGERATOR	400-1000	3.3-8
SHAVER	15-20	0.12-0.16
SPACE HEATER	750-1500	6.25-12.5
STOVE	900-2500	7.5-20.8
TELEVISION	43-600	0.35-5
TOASTER	800-1400	6.6-11.6
WASHER	500-1500	3-4/15-42
WATER HEATER	1000-1500	8-12.5

## **OPERATING MOTOR-DRIVEN APPLIANCES**

When using an appliance with a motor, turn it on and let it reach normal running speed before starting other appliances. Air conditioners, like all electric motors, can draw up to three times more power during the first few seconds of startup than during normal operation. While this is common for all electric motors, it is especially true for air conditioners if the compressor tries to start against built-up high pressure in its refrigeration system.

### **AIR CONDITIONER “SHORT-CYCLING”**

When an air conditioner runs, the compressor builds refrigerant pressure. When the compressor is then shut off, either manually or by satisfying thermostat demand, it must stay off for some period of time, usually 3–4 minutes, to allow pressure in the system to equalize before safely restarting. Trying to restart the air conditioner compressor before pressure equalizes is known as “short-cycling.”

A “short-cycled” air conditioner could 1) trip the air conditioner circuit breaker; 2) shut down the generator due to overload; or 3) trip the air conditioner due to thermal overload. The air conditioner thermal overload will reset itself after the compressor cools. Typically, you cannot manually reset.

Some, but not all, RV air conditioner thermostats have built-in time delays to prevent short-cycling. Short-cycling occurs in some RVs when the thermostat is mounted so that cold air blows directly on it. If this happens, the thermostat shuts the compressor off before the cabin has cooled but quickly warms back up and signals the compressor to restart before refrigerant pressure equalizes. In this case, direct the flow of air from the air conditioner away from the thermostat or relocate the thermostat. You can prevent air conditioner short-cycling by always ensuring the air conditioner rests for 3–4 minutes after the compressor shuts off before trying to restart it.

## **EFFECTS OF HIGH ALTITUDE AND EXTREME TEMPERATURES**

If you travel at high altitudes or in extreme temperatures, your generator can lose power. In such lower-density air conditions, you can't operate as many electrical devices as you could under normal operating conditions.

Power decreases 3.5% for each 1,000 feet above an altitude of 500 feet. For example, to operate at 4,500 feet (4,000 feet above rated generator altitude), multiply  $3.5\% \times 4$  (4,000 ft) = 14% power loss. Then multiply .14 x your generator's power rating: 4,000 watts x .14 = a loss of 560 watts at that altitude.

Power decreases in extreme temperatures by 1% for each 10 °F (5.5 °C) above 77 °F (25 °C).

*NOTE: The carburetor on a non-EFI gasoline generator may require adjustment at high altitudes. (See your operator's manual or your Cummins authorized RV service and parts dealer.)*

## **MANAGING ELECTRICAL LOADS**

If you try to operate too many things at once, you'll "overload" the generator. Your lights will flicker or the circuit breakers on the generator or the main electrical panel will trip open, stopping the flow of power.

Battery chargers replenish power drained from starting the engine and generator or appliances operating on inverter power such as a microwave, refrigerator, mechanical slide out or pump.

Battery charging can aid in overloading your generator, and you may not realize this is happening because the charging starts automatically without any action by you whenever you start your generator.

Typical "invisible" charging loads:

- During startup, air conditioners need "reserve" power and can draw 3–4 times the typical 1,400–2,400 watts needed to run. Too much baseload can prevent air conditioners from starting.
- Battery chargers are activated automatically and can draw a large load (up to 3,000 watts). Manage your electrical loads by adjusting battery charge rates to best suit your needs. Consult your inverter/charger manual or manufacturer.

*NOTE: The generator will continue to run after a circuit breaker trips. Turn off all appliances before resetting the breaker. If the breaker trips again with all electrical loads off, you may have a short circuit in your wiring. Turn off the generator and contact a qualified electrician.*

*EXAMPLE IN CHART BELOW:*

The dashed box below shows that a 2,000-watt inverter running at 100 A battery charge capacity creates the same load as a 13,500 BTU air conditioner plus a microwave oven.

<b>BATTERY CHARGING LOADS</b>					
<b>INVERTER/ CONVERTER SIZE (WATTS)</b>	<b>BATTERY CHARGER MAX OUTPUT (14 VDC)</b>	<b>AMPS REQUIRED FROM GENERATOR (AT 120 VAC)</b>	<b>WATTS</b>	<b>EQUIVALENT APPLIANCE LOAD EXAMPLE</b>	
1000	50 amps	12A	1440	High-efficiency AC or microwave	
1500	75 amps	16A	1920	High-efficiency AC plus microwave	
2000	100 amps	21A	2520	13500 AC plus microwave	
2500	120 amps	26A	3120	15000 AC plus microwave	
3000	140 amps	28A	3360	15000 AC plus microwave	

## **PREVENTING GENERATOR SURGING/HUNTING**

The electrical supply (voltage and frequency) for any appliance must remain within very close limits for it to operate properly. Changes in the generator engine speed (called surging) can damage the appliances in your RV. Proper care of your generator will enable it to supply a stable power source and prevent surging.

RV generator engine speed is controlled with a governing system. Most generators have a mechanical governor, although the latest Cummins EFI and Quiet Diesel generators use an electronic governor. Without a governor, engine speed simply drops as appliances are turned on, until the generator finally stops running. With a governor, the carburetor throttle opens or the EFI system adjusts to compensate for the increased load and thus maintains a constant speed/frequency.

The governor works in careful balance with the generator engine, fuel system, regulator and generator. If the balance is upset, surging may result. A variety of things can cause surging, including an inadequate fuel supply, lack of exercise and poor maintenance. (See the Troubleshooting Guide on pages 36–37.)

## TIPS TO HELP PREVENT SURGING

- Ensure adequate generator fuel supply. Fuel is drawn from a remote fuel tank, which in many cases is usually the vehicle's main fuel tank. Typically the generator's fuel pickup only extends  $\frac{3}{4}$  of the way to the bottom of the tank—to prevent you from completely draining the tank and finding yourself stranded at your campsite! In other words: fuel in the tank does not guarantee fuel to your generator, especially if you have two fuel tanks in your vehicle. A cracked, leaking fuel line or a defective fuel pump can also cause inadequate fuel supply to the generator. Contact your local Cummins authorized RV service and parts dealer to diagnose fuel supply problems.
- Follow the generator exercise recommendations or the out-of-service protection recommendations outlined in your operator's manual. Gum and varnish from stale fuel can plug small carburetor passages, causing a lean fuel mixture and surging. Treat the fuel system with a good quality fuel system cleaner in the clean-up mode ratios. Contact your local Cummins RV service and parts dealer to have the carburetor cleaned and adjusted or replaced if the problem persists.
- Adjustment should be done on gasoline or the LP model's carburetor, choke and governor by your local Cummins authorized RV service and parts dealer, who has specialized instruments made specifically for this job.
- If your generator continues to surge, take it in for service and do not operate. Damage could occur to your electrical devices in the RV and to the generator.

**! CAUTION: When operating electronic appliances (TVs, computers, etc.) in your RV, it is important to use surge protectors to prevent power surges from damaging your equipment. Cummins is not responsible for damage to sensitive electronic equipment.**

# INSTALLED CUMMINS GENERATORS ARE EXCEPTIONALLY QUIET

Noise comparison chart (in decibels\*)

Onan RV QD 3200 72 dBa  
 Onan RV QG 2800 72 dBa  
 Onan RV QG 5500/7000 68/70 dBa  
 Onan RV QD 10000/12500 68/70 dBa  
 Onan RV QG 4000 68 dBa  
 Onan RV QD 6000/8000 66 dBa  
 Measured at 10 ft at half load

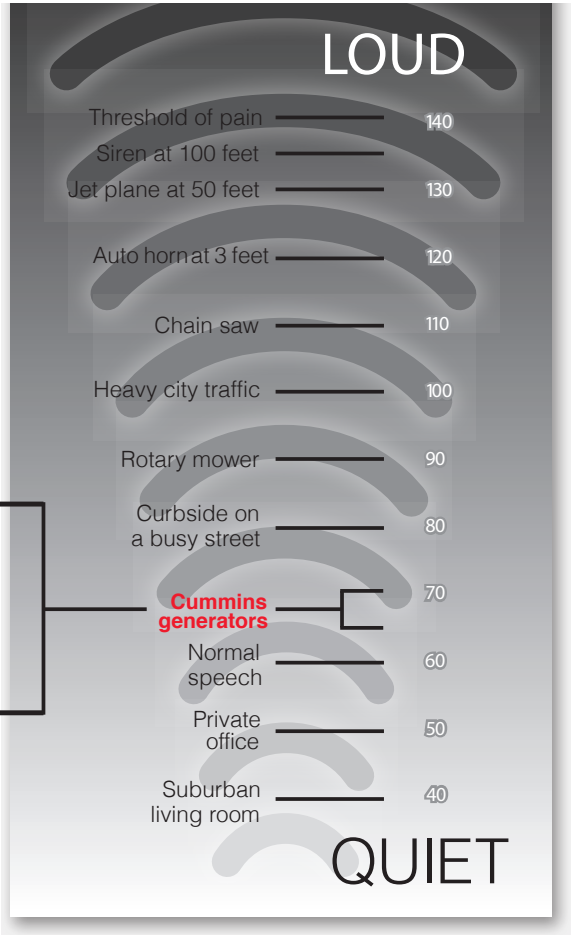



## 4 | FREQUENTLY ASKED QUESTIONS (FAQS)

**Q:** *Can a generator charge my RV house battery?*

**A:** Not directly. But a generator does provide power to operate your converter/charger, which charges batteries.

**Q:** *Is it practical to power the roof air conditioner with my generator while traveling on the road?*

**A:** Yes, that is what a generator is for: portable electrical power. In fact, it can help lower fuel consumption because the generator uses less fuel than your vehicle engine. Plus, it gives you an opportunity to exercise your generator. Any appliance that can be run in a stationary position can also be powered while driving.

**Q:** *Why does a breaker trip and one air conditioner not work when I turn it on while the generator is running?*

**A:** Some RVs with two air conditioners have a 20-amp circuit breaker for the rear air conditioner and a 30-amp breaker for all other loads (including the front air conditioner). The RV may be wired with the two circuits reversed, causing the breaker to trip. The generator connections and wiring should be checked at an authorized service location.

**Q:** *Is generator power clean enough to run a laptop?*

**A:** Yes, with Cummins generators, this is no problem. The set should be turned on and warmed up before turning on the computer. The normal precautions for home use should be followed for RV use as well.

Q: *Can I operate an air conditioner and microwave at the same time?*

A: Although this is possible in lower temperatures or altitudes or with high-efficiency ACs, Cummins 2,500- and 2,800-watt generators will probably be overloaded when the AC cycles off and on with the microwave running. Load-shedding devices are available that automatically turn off the AC when the microwave starts and then restarts it when power is available again. All other Cummins generators can operate both of these appliances at the same time.

Q: *Will high-efficiency (power saver) air conditioners provide more reserve power?*

A: Yes. High-efficiency ACs use 30% less power and are easier to start. That means more power is available for use in the RV or for better fuel economy. High-efficiency ACs also have higher cooling output than comparable standard ACs.

Q: *What happens if I “short-cycle” my air conditioner?*

A: Short-cycling refers to stopping and restarting the air conditioner compressor before the refrigerant pressure has enough time to equalize. If this happens, one of several things can occur: a circuit breaker may trip, either on the generator or at the breaker panel; the generator engine may stall; or the AC compressor may trip its overload. AC compressors should remain off for at least three minutes before being restarted.

Q: *Can I run an RV generator in a national park?*

A: Yes. Cummins-installed generators are quieter than the national park sound level requirements (during allowable hours of use).

Q: *Why do I want to exercise my genset?*

A: Regular exercising of the genset heats up the alternator windings and removes or expels excess moisture. In sets equipped with brushes, exercising helps prevent corrosion buildup on slip rings. Running the genset also brings fresh fuel to the carburetor on gasoline and diesel gensets.

Q: *How often do I need to exercise my gasoline / diesel / LPG generator?*

A: Ideally, Cummins generators should run two hours every month. Once the genset is started, add as much load as possible (i.e., air conditioner, heat pump, hair dryers, other appliances). The objective is to place a 50 to 70 percent load on the genset.



Q: *I will not be using/exercising my generator every month. What do I need to do?*

A: LPG- No special requirements.

Gasoline- Depending upon your location in the country, gasoline can start to deteriorate in as little as 30 days. Treat the entire fuel tank with gasoline stabilizer. Run the genset for two hours at 50 to 70 percent load. This process will circulate the treated fuel through the entire fuel system.

Diesel- Diesel is a very stable fuel. If the recreational vehicle will be in storage for greater than six months, treat the entire fuel tank with a diesel stabilizer. Run the genset for two hours at 50 to 70 percent load. This process will circulate the treated fuel through the entire fuel system.

Q: *How are “will-fit” generator replacement parts different from Green Label Parts™?*

A: Cummins genuine Green Label Parts are tested and designed specifically for RV applications. Will-fit parts and gaskets can be the correct shape, but because of inadequate design, the wrong material or poor quality, they could cause premature failure, leakage or performance problems. Use of some non-Cummins replacement engine parts may affect the unit's emissions certification, and damage caused by use of oil and air filters other than Green Label Parts is not covered under your generator warranty.

Q: *How often should I perform maintenance on my generator? Will doing it myself affect my warranty?*

A: The operator's manual that accompanies each generator outlines the proper maintenance intervals and procedures for your generator. Proper maintenance is required to ensure warranty coverage remains intact. Maintenance may be performed by any engine repair establishment or individual. It is advised to keep a log of maintenance performed on your generator.

Q: *What should be done to the generator oil before putting the generator in long-term storage?*

A: Before putting the RV in long-term storage, change the oil of the generator to match the anticipated temperature conditions when it will be put back in service.

Q: *Should I use straight 30-weight oil, or is the multi-viscosity oil I use in my vehicle okay?*

A: Yes, it is OK to use multi-viscosity oil or 30 W for temperatures above 32 °F. For more detailed instructions on what type of oil to use, consult the chart on page 33.

- Q: *Will high-octane gasoline reduce the amount of fuel varnish?*
- A: No, because varnish is a form of fuel degradation that is not a function of octane level. Rather, it is a function of fuel quality, age and additive treatment. High-octane fuel without stabilizer additive will oxidize or varnish at a faster rate than fuel treated with a fuel stabilizer.
- Q: *When I'm checking my oil, does the dipstick need to be screwed in all the way?*
- A: In order to get the correct oil level reading, the dipstick must be screwed in completely on all models with a screw-type dipstick, except for the Onan RV QG 2800/2500 model; it sits on top of the fill tube. Make sure the vehicle is level when checking oil level.
- Q: *How do I keep mice/rodents out of my generator during storage?*
- A: Use rodent prevention techniques around the generator/compartments just as you would with any other area of your RV.
- Q: *Can I use my 4000-watt generator to run two air conditioners?*
- A: No.
- Q: *Will the starter motor continue to be engaged if the start button is held too long?*
- A: All Cummins generators are equipped with a start disconnect feature, which will not allow the starter to crank once the generator is producing electrical output.
- Q: *Why don't I have as much power as I think I should?*
- A: Your power might vary with conditions such as load and altitude. Battery chargers run as "invisible" loads and can draw as much power as two air conditioners, depending on size. This can continue for several hours, depending on battery charger and battery bank size. (See the Battery Management section on page 17–18 for more information.)
- Q: *Why does my generator surge at startup?*
- A: Depending on the ambient conditions, the generator may surge until it reaches a stable operating temperature.
- Q: *Can I use synthetic oil in my generator?*
- A: People use synthetic oils because the general opinion is that they can be left in the engine longer than regular oil. However, if you decide to use synthetic oil in your generator, the maintenance time intervals given in the operator manuals must still be followed.

---

## LP GENERATORS

**Q:** *Should I get an LP or a diesel generator for my diesel motorhome? What are the differences?*

**A:** Each fuel option has its own advantages. LP generators generally have a lower initial cost than diesel units. In addition, they're smaller and lighter weight, allowing for more flexibility in the floor plan of large RVs. LP generators also have less exhaust fume smell. Diesel generators have a much longer engine life. They consume less fuel, and diesel fuel usually costs less than LP, which brings additional savings. A diesel generator gives you a common fuel system and the convenience of operating your generator from the vehicle's main fuel supply. The generator best for you depends on how you use it and your own personal preferences.

**Q:** *How is LP fuel supplied to my generator?*

**A:** LP fuel is stored in its own fuel tank in liquid form with some vapor at the top of the tank at relatively high pressure. The pressure in the tank is determined by the ambient (outdoor) temperature. The higher the temperature, the higher the pressure. Ambient heat vaporizes fuel until the pressure won't allow any more liquid to vaporize. The tank pressure will be about 200 psi at 110 °F, 70 psi at 40 °F and 0 psi at -40 °F (-40 °C).

In order for the fuel to be burned at a controlled rate in the generator (or any other appliance), it must be converted to a vapor form and supplied at a controlled pressure.

LP fuel systems for Cummins generators use vapor withdrawal.

**Q:** *Can LP fuel plug up the regulator?*

**A:** The most common contaminants found in LP fuel are the oils from the LP pumping facility. Oil can accumulate in the regulator on Cummins generators. Oil in the regulator can cause hard starting and surging. Contact your Cummins dealer for service. Never attempt to clean or adjust an LP regulator.

---

## ELECTRONIC FUEL INJECTION (EFI) GENERATORS

Q: *How reliable is the technology for electronic fuel injection? Will I have more problems?*

A: No, you won't have more problems. Actually, you'll have less. The EFI technology used in our Onan RV QG models is the same technology used in the automotive industry for more than 30 years.

Q: *Should I worry about gumming of the fuel system with my EFI generator?*

A: No. Your EFI generator minimizes fuel system gumming. This will minimize maintenance and service requirements and make storage of your RV much simpler.

Q: *Does a generator with EFI start better?*

A: The Onan RV QG generator is much faster and more reliable in both hot and cold starting. This will result in fewer start failures.

Q: *Do I have to adjust for altitude and temperature with EFI?*

A: No, the Onan RV QG EFI generator has automatic altitude and temperature compensation.

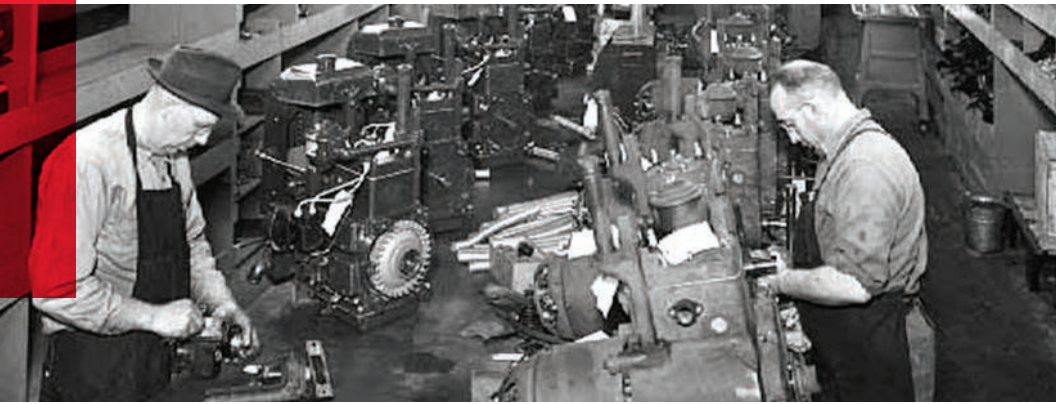

## 5 | GENERATOR CARE AND MAINTENANCE

A Cummins RV generator is an investment that can bring you many years of comfort and enjoyment. However, all generators require periodic maintenance for dependable, ongoing performance. Your operator's manual outlines the specific maintenance procedures and service intervals for your particular model. Take good care of your generator, and it will take good care of you.

RV maintenance is performed according to the number of miles you travel. Similarly, generator maintenance is based on hours of running time. If your generator does not come equipped with an hour meter, install one and place it in an easy-to-see location near the RV's electrical control panel so you can keep track of the hours your generator runs. The Cummins deluxe remote control panel includes an hour meter. The chart on page 29 shows the recommended maintenance intervals for Cummins generators. These are general guidelines only. Consult the operator's manual for procedures and maintenance intervals for a specific model. Replacement operator manuals can be found by creating a free account on [quickserve.cummins.com](https://quickserve.cummins.com).

- Maintenance charts are printed in all operator's manuals.
- Check your generator exhaust system each time you start the generator. Make sure it doesn't leak and that it extends beyond the vehicle's perimeter.

## RV GENERATOR MANUALS

	SERIES	SPEC LETTER	OPERATORS	PARTS	SERVICE	INSTALLATION
RV QD 3200	HDZAA	A-E	983-0103	983-0203	983-0502	983-0602
RV QD 5000	HDKBA	A-D	981-0166	981-0271	981-0535	981-0633
RV QD 6000	HDKAH	A-K	A046L053	981-0200	981-0522	A046L051
	HDKAH	L-P	A046L053	A029S789	981-0522	A046L051
RV QD 7500	HDKAJ	A-K	A046L053	981-0200	981-0522	A046L051
RV QD 8000	HDKAK	A-K	A046L053	981-0200	981-0522	A046L051
	HDKAK	L-P	A046L053	A029S789	981-0522	A046L051
RV QD 10000	HDCAA	A-B	981-0152	981-0259	981-0526	981-0615
	HDCAA	C-D	981-0170	981-0259	981-0526	981-0637
	HDKCA	A-E	981-0173	981-0277	981-0540	981-0640
	HDKCA	F-H	A043D713	A043T420	A043M526	A043D717
RV QD 12500	HDCAB	A-B	981-0152	981-0259	981-0526	981-0615
	HDCAB	C-D	981-0170	981-0259	981-0526	981-0637
	HDKCB	A-E	981-0173	981-0277	981-0540	981-0640
	HDKCB	F-H	A043D713	A043T420	A043M526	A043D717
HQD 810	HQDSA-810	A-C	0981-0178	981-0286	981-0545	981-0645
HQD 1218	HQDSB-1218	A-B	981-0179	981-0283	981-0546	981-0646
RV QG 2500 LP	KV	A-B	981-0129	981-0238	981-0506	981-0626
LP/2800/2800 EVAP	KV	C-D	981-0136	981-0238	981-0518	981-0604
	KV	E-M	981-0153	981-0238	981-0518	981-0604
	KVC	A-C	981-0158	981-0238	981-0518	981-0620
	HGJBB	A-B	A031C171	A035B506	A031C173	A031C172
RV QG 2500 LP/ RM/2800 RM	KVD	A-C	981-0164	981-0238	981-0518	981-0631
RV QG 3600 LP /4000	KY	A	981-0132	981-0246	981-0503	981-0627
	KY	B-C	981-0139	981-0246	981-0503	981-0607
	KY	D-H	981-0154	981-0246	981-0530	981-0607
	KY	J-N	981-0159	981-0246	981-0530	981-0621
	KY	P-R	A041D131	981-0246	A041D133	A041D129
	KYD	A-C	981-0169	981-0246	981-0530	981-0636
RV QG 5500 EFI/7000 EFI	HGJAA	A-E	983-0101	983-0201	983-0501	983-0600
	HGJAA	J-K	A035D009	983-0201	A035D011	A035D005
RV QG 5500/5500 EVAP 7000/7000 EVAP	HGJAB	A-E	983-0101	983-0201	983-0501	981-0600
	HGJAB	J-L	A035D009	983-0201	A035D011	A035D005

## GENERAL GENERATOR MAINTENANCE INTERVALS

MODEL	SERVICE INTERVALS—REPEAT EVERY				
Service item	Monthly	50 hrs	150 hrs	450 hrs	500 hrs
<b>RV QG (GASOLINE / LP)</b>					
Clean and check battery and connections	X <sup>3</sup>				
Clean spark arrester (HGJBB only)		X <sup>5</sup>			
Change oil / oil filter			X <sup>1-4</sup>		
Change air filter			X <sup>2,5</sup>		
Replace spark plugs				X <sup>5</sup>	
Change fuel filter				X <sup>5</sup>	
Schedule Cummins service center tune-up*				X <sup>5</sup>	

MODEL	SERVICE INTERVALS—REPEAT EVERY				
Service item	Monthly	150 hrs	250 hrs	500 hrs	1000 hrs
<b>RV QD (DIESEL)</b>					
Clean and check battery and connections	X <sup>3</sup>				
Change oil / oil filter — QD 3200 / 10000 / 12500			X <sup>1-4</sup>		
Change oil / oil filter — QD 5000 / 6000 / 7500 / 8000 — HQD 810 / 1218		X <sup>1-4</sup>			
Change air filter				X <sup>2,5</sup>	
Flush coolant system — Quiet Diesel					X <sup>8</sup>
Change fuel filter — Quiet Diesel				X <sup>5</sup>	

1. As a part of engine break-in, change the engine oil after the first 20–50 hours of operation or within the first year of ownership.
2. Perform more often when operating in dusty environments.
3. Perform more often when operating in hot weather.
4. Perform at least once a year.
5. Perform sooner if engine performance deteriorates.
6. Should be performed by a qualified mechanic (Cummins authorized RV service and parts dealer).
7. Perform at least once every five years.
8. Perform every 75 hours when using high-sulfur fuel (typically found only in the Middle East).

\*Not performing scheduled maintenance may void your warranty.

*NOTE: Perform a general inspection and check oil daily per maintenance schedule in operator's manual.*

# DOS AND DON'TS FOR BETTER GENERATOR PERFORMANCE

## THE DOS

DO keep your generator clean by wiping it periodically with a clean cloth.

DO turn off all appliances before starting your generator for best long-term performance.

DO check operator's manual for periodic maintenance schedule.

DO check the exhaust system regularly for damage or leaks. Make sure the exhaust pipe extends out at least one inch beyond the vehicle's perimeter.

DO check the air filter periodically and clean it by tapping it on a flat surface. Never wash it in solvents or blow it out with an air hose.

DO install a running hour meter, if not already present, and ensure it's operating properly. This will help you know when scheduled maintenance service is due.

DO exercise your generator regularly.

DO make sure that clean fuel, the most important factor for proper generator performance, is used. Refer to the fuel recommendations covered on page 31.

DO make sure each operator is familiar with the important safety precautions listed on pages 4 and 5.

DO change your fuel filter. The fuel filter is an often forgotten part of any engine. Your generator has one too. It removes bits of debris from the fuel to prevent clogging the carburetor jets. Over time, the fuel filter collects enough material to become plugged, which restricts fuel flow and reduces the generator's power delivery. Be sure to change the fuel filter on a regular maintenance schedule.

## THE DON'Ts

DON'T run the generator for long periods of time without using it to power appliances. It wastes fuel and may cause the engine to misfire.

DON'T attempt to adjust the carburetor, governor, choke, etc. yourself. See your Cummins authorized RV service and parts dealer for assistance.

DON'T run your generator set with the generator door panel removed.

DON'T run your generator on roads when there is heavy pooling of water.



# KEEP YOUR GENERATOR CLEAN AND INSPECT IT REGULARLY FOR DAMAGE

Your RV generator is a hardworking device that lives in an unfriendly environment, typically in the underside of your RV. Dust and debris are a part of its daily life. Dust can clog the intake system and reduce its engine's efficiency. Remember to replace air and oil filters regularly.

Over time, vibration from rough roads can loosen generator fasteners while debris thrown up from the road can occasionally damage fuel lines and exhaust systems. It makes good sense to regularly inspect all these items. Do not use a water hose or high-pressure car-wash-type sprayers on the generator. Light air pressure and a damp cloth are preferred.

## FUEL RECOMMENDATIONS

**Gasoline generators**-Treat the engine of your Cummins generator with a good grade of regular unleaded gasoline, and it'll purr in response. You can also use Gasohol (gasoline blended with alcohol) if it contains the correct additive mixture percentages:

- Ethanol blend-Not more than 10% ethanol
- Methanol blend—Not more than 5% methanol, and the fuel must also contain solvents and corrosion inhibitors

*NOTE: Fill up with fresh gas! A very common service issue is stale or contaminated fuel. Always use fresh gas! The gas should not be more than 30 days old. Fuel stabilizer extends the life of your fuel. Stale fuel clean-out is not covered under your warranty. Exercising your generator also helps keep the fuel fresh in the generator.*

**LP generator**-Use clean, HD-5 grade liquid propane in a mixture of at least 90% propane. Propane fuels other than HD-5 can contain more than 2.5% butane which can result in poor fuel vaporization and poor engine starting in outside temperatures below 32 °F.

**Diesel generators**-Use any of the following ASTM-certified fuels for your quiet diesel:

ASTM-No. 2-D	(ambient temperature greater than 32 °F)
	(No. 2 Diesel)
or ASTM-1-D	(No. 1 Diesel)
No. 2-DLS	(ambient temperature greater than 32 °F)
No. 1-D	(ambient temperature less than 32 °F)
No. 1-DLS	(ambient temperature less than 32 °F)
B5 Biodiesel	(ambient temperature greater than 50 °F)

Ensure the fuel selected for use has a minimum Cetane number of 45. No. 2-D or No. 2-DLS diesel fuel gives the best economy and performance under most operating conditions. Use No. 1 diesel fuel when ambient temperatures are below 32 °F and during long periods of light engine load. Use low-sulfur or ultra low-sulfur content fuel having a cloud point of at least 10 °F below the lowest expected fuel temperature. Cloud point is the temperature at which wax crystals begin to form in diesel fuel.

**B20 biodiesel**-The use of B20 biodiesel requires the generator to have an additional fuel/water separator. Long-term storage of biodiesel fuels can result in oxidation and/or mold growth. Consult your vehicle manufacturer and your generator owner's manual to see if this option is applicable to your generator.

3200 QD is approved for B5 biodiesel only.

## OIL RECOMMENDATIONS

Oil changes are important. The first break-in oil change is critical to the longevity of the generator. Use a premium, quality engine oil (such as OnaMax™ in the correct oil viscosity for your generator's typical operating temperature range to provide optimum engine service. Avoid mixing different grades or brands.

It's good practice to check the oil level daily or every eight hours of operating time. Keep the oil level as near as possible to full, but do not overfill. Overfilling may cause foaming and engine shutdown. Replace the cap tightly to prevent leakage. And if your generator has an oil filter, change it when you change the oil.

DO NOT check the oil level while the generator is running because hot oil can be thrown out of the dipstick hole, causing severe burns.

- **Gasoline engine oil quality**-Use oil meeting any of the following API performance categories: SM or SN, where SN is currently the highest quality available. Look for the "Energy Conserving" designation to optimize fuel economy.
- **Diesel engine oil quality**-Use oil meeting any of the following API performance categories: CF, CF-4, CG-4, CH-4, CI-4 or CJ-4 where CJ-4 is currently the highest quality available. The use of oil meeting API performance category CF-4, CG-4, CH-4 or CI-4 while burning fuel with a sulfuric content greater than 0.5% or CJ-4 while burning fuel with a sulfuric content greater than 0.0015% is not recommended, as oil service is negatively impacted.
- **Oil viscosities**-Use the following chart to select correct viscosity grades for expected ambient temperature range.

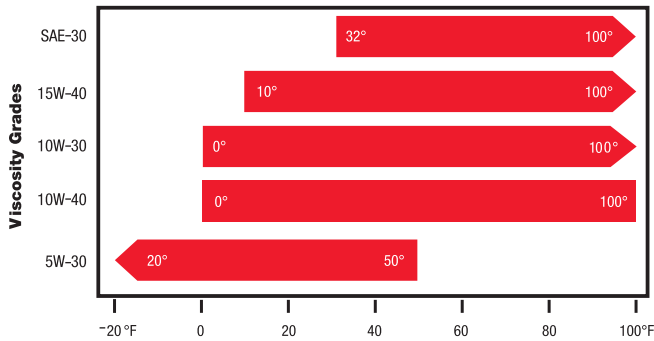

*10W-30: preferred oil for Gasoline/LP Generators*

*15W-40: preferred oil for Diesel Generators*

*NOTE: All generators are shipped from the factory with 15W-40 oil, 10W-30 for gas.*

## COOLANT RECOMMENDATIONS

The quality of the coolant in your liquid-cooled generator is an important factor in performance and service life. Always use a 50/50 mixture of ethylene glycol-based antifreeze and water, which should be mixed thoroughly before adding to the generator's cooling system.

- **Water**-Use clean, soft water, distilled water or pure rain in your mixtures. If hard water or other forms of natural water are used, your generator's cooling system is more liable to oxidize, corrode and create deposits faster.
- **Antifreeze**-The core components of ethylene glycol-based antifreeze are acidic. Introduction of the cooling water creates alkaline properties that can rapidly corrode light metals. Be sure to select high-quality antifreeze with corrosion inhibitors to prevent cooling system problems. Also, be sure to maintain the cooling system, as use of antifreeze coolant for an extended period of time can result in increased corrosion.

In diesel applications, you can use the same coolant in your drive engine as your diesel generator. **BUT DO NOT MIX DIFFERENT TYPES OF COOLANT.**

## PREVENT FUEL VARNISHING

Fuel varnishing is a gummy residue that clogs the generator carburetor and fuel pump. It's caused by the deterioration of fuel that sits in the engine or fuel tank too long. This can happen in a surprisingly short period of time. Depending on fuel quality and storage conditions, modern blended gasoline fuels can deteriorate in as little as 30 days. As long as you refuel frequently with fresh gasoline and exercise the generator regularly, fuel varnishing is

less likely to occur. But if you leave the same gasoline in the tank for several months, you're very likely to have problems.

Fuel varnishing affects all engines, but it's more noticeable in generators because the engines are smaller. Even the slightest decrease in efficiency has a big impact on performance. A generator with varnish buildup may start but run like it needs a tune-up. It surges, accelerating and decelerating, but rarely settles at a stable operating speed. In many gasoline-powered units, the engine speed directly affects generator voltage output and frequency. As speed increases/decreases, so does the voltage and frequency.

One way to prevent fuel varnishing is to treat the contents of the tank supplying fuel to the generator with a fuel preservative and exercise the set. Cummins has developed a fuel preservative and stabilizer, OnaFresh™, specifically formulated for our generators. We recommend adding this preservative to the fuel, especially on infrequently used RVs. If stabilizer is added to the RV tank, the generator must then be exercised to pull the treated fuel into the generator's engine.

Tips to prevent generator fuel varnishing when storing your RV or for infrequent use (if you don't go through a full tank of fuel in less than 30 days):

- Treat your fuel tank with a preservative like OnaFresh™, then exercise your generator.
- Run the generator dry, then drain its carburetor float bowl.

To drain the float bowl, do the following:

- a. Let the engine cool down thoroughly.
- b. Place paper towels under the drain to absorb all of the drainage (less than ½ cup).
- c. Open the drain valve by turning it counterclockwise with a screwdriver.
- d. Close the drain valve after draining the carburetor by turning it clockwise with a screwdriver until just snug.

**⚠ CAUTION: Do not open the carburetor drain when the engine is hot. Close the drain immediately after draining. Failure to heed this warning can lead to fire, resulting in severe personal injury or death.**

Once varnishing has occurred, adding a preservative won't correct the problem.

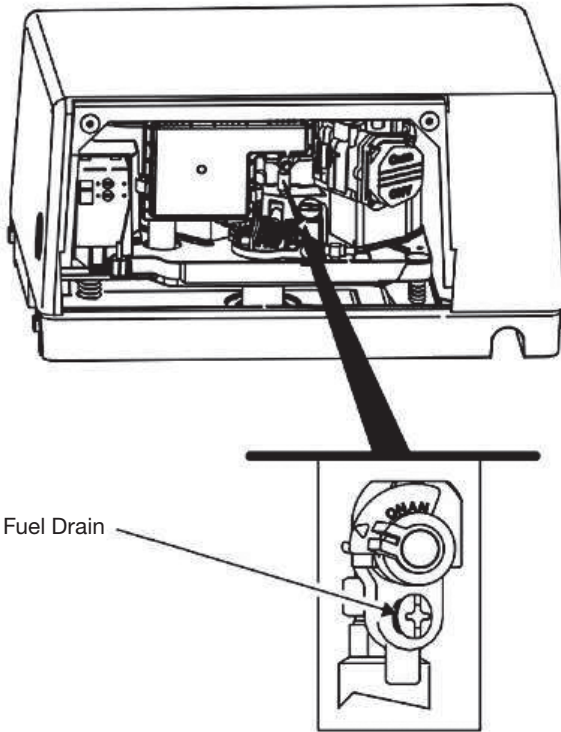

Fuel Drain

By understanding how to properly care for your RV generator and protect against fuel varnishing, you'll enjoy better performance and longer, service-free operation.

OnaFresh™, along with other Green Label Parts maintenance products, can be found at your local Cummins authorized RV service and parts dealer. To locate your nearest dealer: [power.cummins.com/sales-service-locator](http://power.cummins.com/sales-service-locator).

**IMPORTANT: Problems caused by fuel varnishing will not be covered under warranty.**

# TROUBLESHOOTING GUIDE

Under normal operating conditions, you can expect your Cummins generator to perform reliably without problems. But if a problem does occur, you may be able to isolate the cause by using the following troubleshooting chart.

If you cannot discover and correct the problem, make a note of your generator model and serial numbers and contact your local Cummins authorized RV service and parts dealer.

TROUBLESHOOTING GUIDE		
PROBLEM	PROBABLE CAUSE	SOLUTION
Fails to crank	Low battery.	Charge battery or replace defective battery.
	Bad battery connection.	Clean and tighten all battery and cable connections.
	Faulty starter.	Contact your Cummins authorized Onan RV service dealer.
Crankes slowly	Low battery.	Check battery voltage at generator.
	Bad battery connection.	Clean and tighten all battery cable connections.
	Incorrect oil viscosity.	Replace with recommended viscosity oil.
	Load connected.	Disconnect load before starting.
Crankes but won't start	Fuel below generator pickup level in tank.	Add fuel.
	Carbon deposits on spark plug(s).	Remove spark plug(s) and replace.
	Low oil level.	Add oil.
Exhausting black smoke	Dirty air filter.	Replace air filter.
	Choke stuck or misadjusted.	Contact your Cummins authorized Onan RV service dealer.
Unit runs then stops, or stops when driving around a corner	Low fuel level.	Add fuel.
	Low oil level.	Add oil.
	Excess oil.	Reduce engine oil level.
Diesel excessive smoke on start-up	Faulty glow plug.	Contact your Cummins authorized Onan RV service dealer.

TROUBLESHOOTING GUIDE		
PROBLEM	PROBABLE CAUSE	SOLUTION
Unit starts and runs, then stops when the start switch is released	Low oil level.	Check and bring all oil up to the appropriate levels.
	No AC output.	Contact your Cummins authorized Onan RV service dealer.
Unit runs then surges	1. Loose or worn spark plug leads.	1. Check spark plug leads at spark plug and ignition coil.
	2. Defective ignition coil, wiring or control components.	2. Contact your Cummins Authorized Onan RV service dealer.
	3. Faulty spark plug.	3. Remove spark plug and clean or replace.
	4. Governor out of adjustment.	4. Contact your Cummins Authorized Onan RV service dealer.
	5. Combustion air preheat malfunction.	5. Contact your Cummins Authorized Onan RV service dealer.
	6. Carburetor icing.	6. Move carburetor pre-heater to the winter position.
	7. Carburetor varnishing.	7. Try fuel system cleaner and contact dealer if no change.
Circuit breaker trips	Overloaded circuit.	Turn off some of the electric load and reset the circuit breaker.
	Tripped circuit breaker.	Reset the circuit breaker. Check at distribution panel and genset.
No electricity in coach	Automatic Transfer Switch failure.	Possible issue with Coach's Automatic Transfer Switch. Contact your Cummins Authorized Onan RV service dealer.
No electric output at generator	Other issue.	Contact your Cummins Authorized Onan RV service dealer.

**WARNING! Incorrect troubleshooting procedures can result in risks of property damage or death from fire, explosion, electrocution and asphyxiation or being caught or hit by moving parts. DO NOT ATTEMPT TROUBLESHOOTING unless you are trained and experienced in electrical and mechanical maintenance.**

# FAULT CODES

EXCEPT RV QD 3200

The genset controller provides extensive diagnostics by causing the status indicator light on the Start/Stop Control Switch to blink in a coded fashion. Anytime the generator shuts down without a stop button being requested, a fault will be generated. Following a fault shutdown, the indicator light will repeatedly blink one, two, three or four blinks at a time.

- One blink indicates shutdown due to high engine coolant temperature.
- Two blinks indicates a low oil pressure fault.
- Three blinks indicates a service fault. Press Stop once to cause the two-digit, second-level fault code to blink. (Pressing Stop again will stop the blinking.) The two-digit code consists of one, two, three, four or five blinks, a brief pause and then one to nine blinks. The first set of blinks represents the tens digit and the second set of blinks is the units digit of the fault code number. For example, Fault Code No. 36 appears as: blink-blink-blink—pause—blink-blink-blink-blink-blink-blink—long pause—repeat\*\*.

*\*\*A common service fault code is 36. Code 36 means that the generator shut down but was not 'told' to shut down by the control. Usually this means the generator is not getting fuel. Check fuel level, filter and hoses.*

- Four blinks indicates that cranking exceeded 30 seconds without the engine starting.

*NOTE: Fault Code Nos. 3 and 4 are first-level faults. Avoid interpreting them as second-level Fault Code Nos. 33 and 44, which have not been assigned as fault codes.*

**Restoring Fault Code Blinking**—The fault code stops blinking after five minutes (15 minutes, Series HGJAA). Press Stop three times within five seconds to restore blinking. Note that the last fault logged will blink, even after the condition that caused the shutdown has been corrected.

Fault codes are a key element to determining what is happening with your generator; however, not all fault codes indicate a serious condition. When requesting service, knowing your last fault code will greatly help in a quick and accurate diagnostic. A more complete answer can be given if you know the answer to this question.

For a complete list of all the fault codes, please refer to the operator's manual.



# RV QD 3200 CONTROL PANEL MAINTENANCE MESSAGES

- CHECK OIL LEVEL - Every 20 hours
- CHANGE OIL - At 50 hours and then every 250 hours

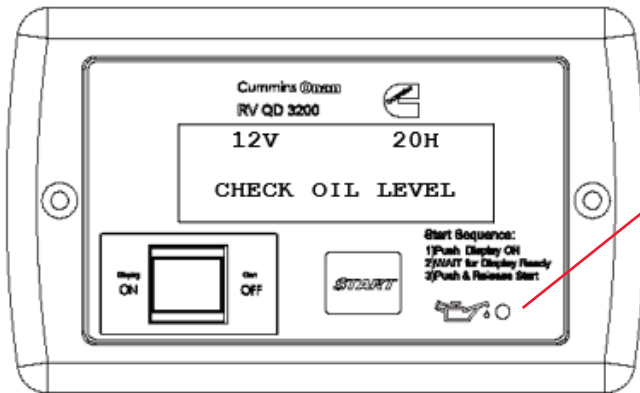

Low Oil  
Pressure/High  
Oil Temperature  
Shutdown Light

## OIL CHANGE/CHECK OIL LEVEL

ALARM	TIME PERIOD	WHAT THIS MEANS	GENERATOR RESPONSE	HOW TO RESET
Check Oil Level	Every 20 Hours	Reminder to check your oil level	None - Just a warning	Press Start and Hold when generator is running until message clears
Change Oil	First time at 50 Hours and then every 250 Hours	Reminder to change your oil	None - Just a warning	Press Start and Hold when generator is running until message clears
Oil Indicator Light – Low Oil Pressure or High Oil Temperature	NA	Low oil pressure or High oil temperature	Shutdown	Resets on restart after a period of time

If Check Oil Level or Change Oil is not reset, it will reappear after an hour of running and every time the generator is started.

# SERVICE DIAGRAMS

ONAN RV QG 2500 LP/2800 (HGJBB)

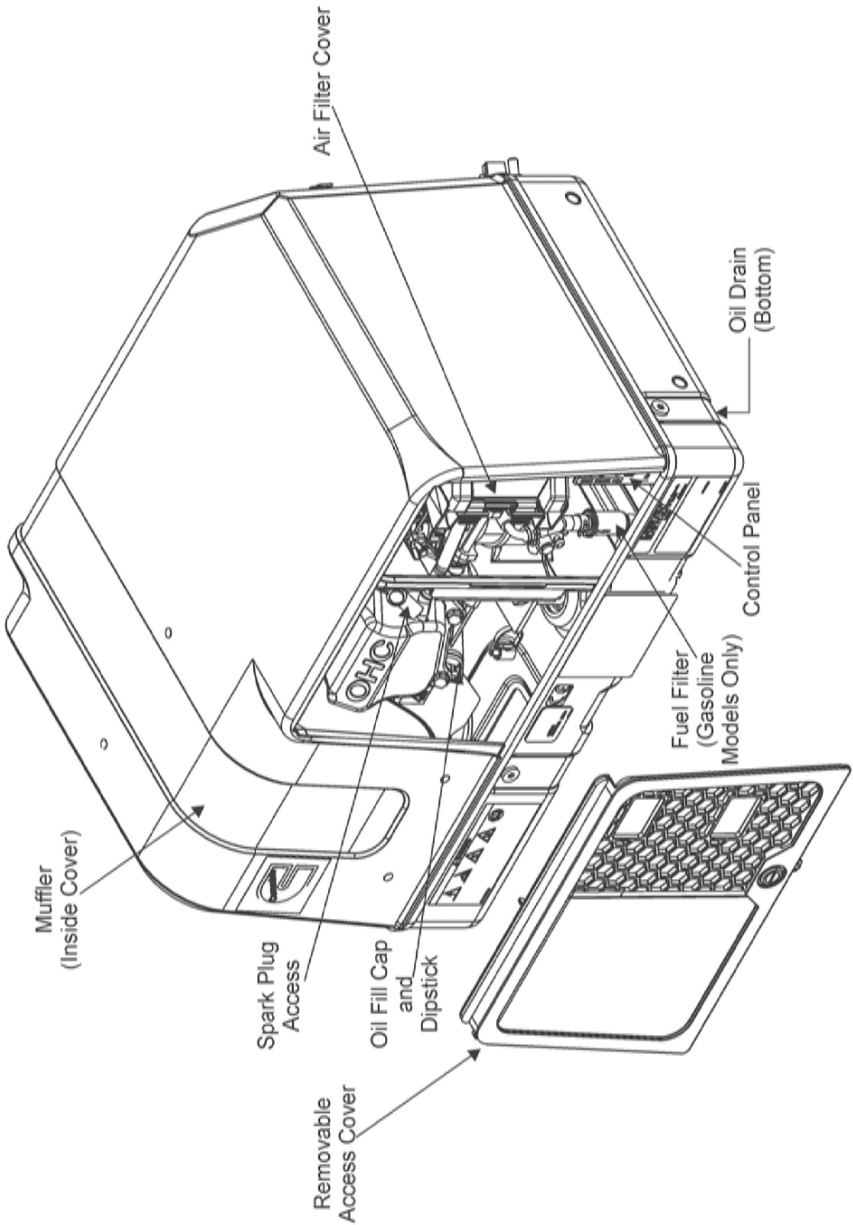

ONAN RV QG 3600 LP/4000

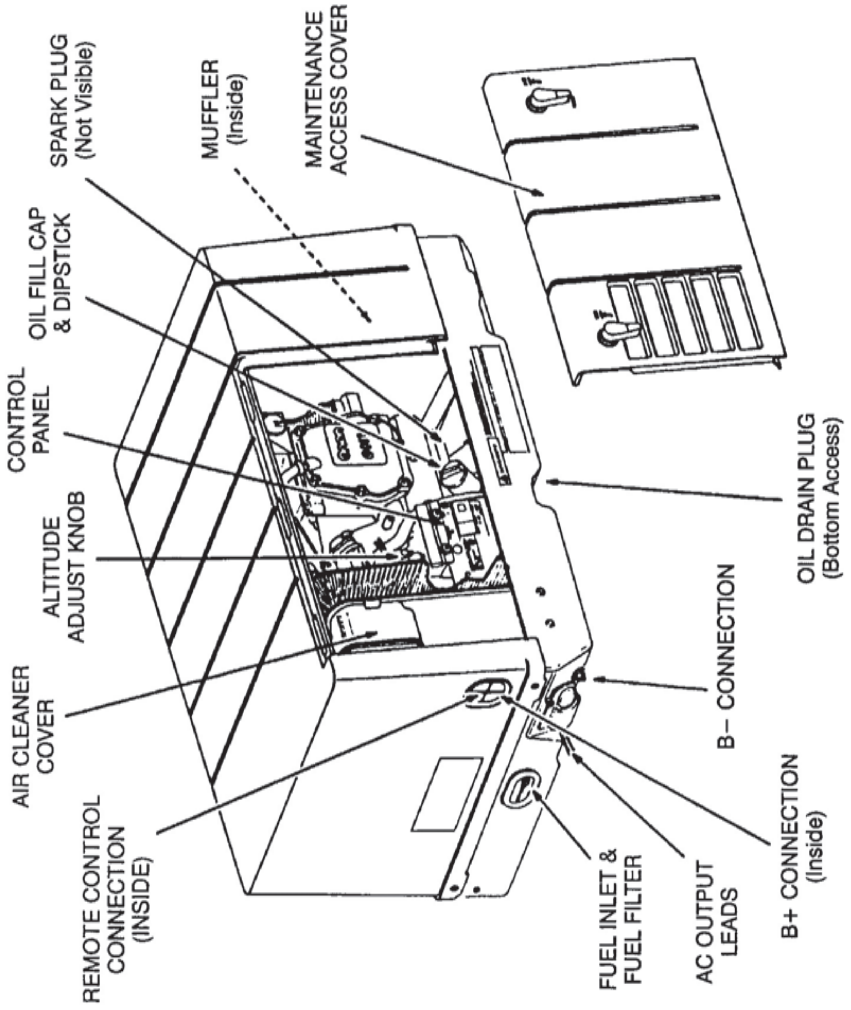

ONAN RV QG 5500/7000

ONAN RV QG 5500 EFI/7000 EFI

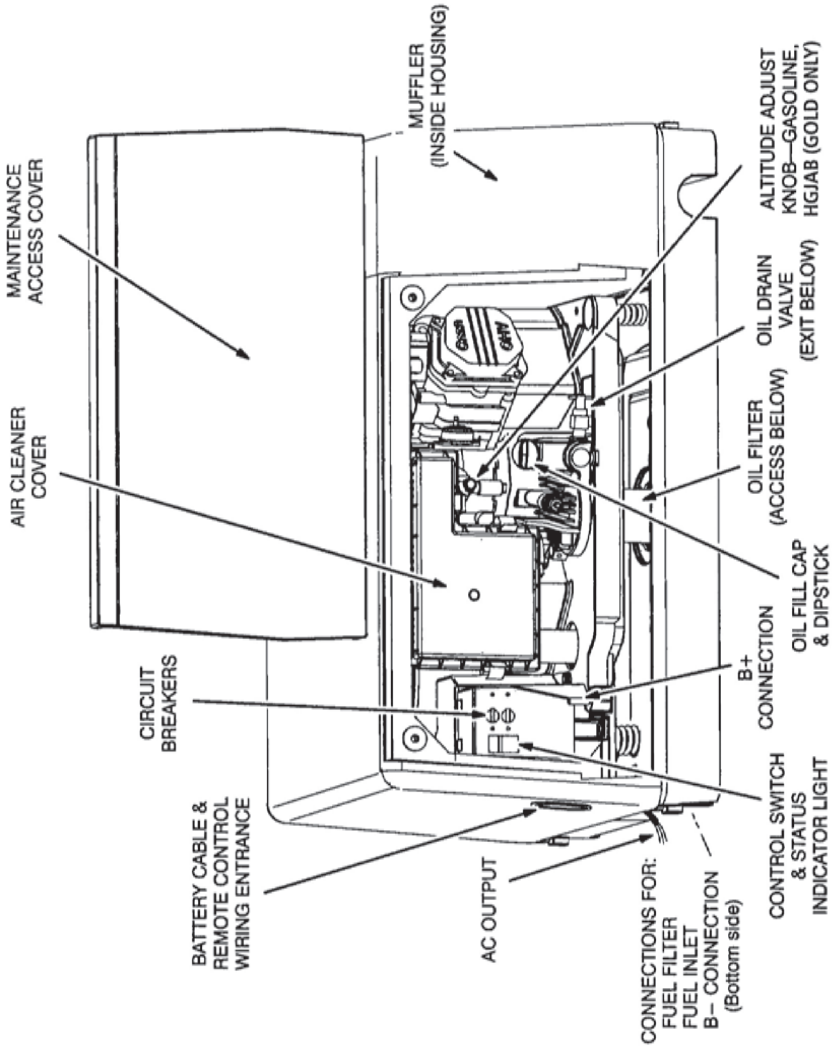

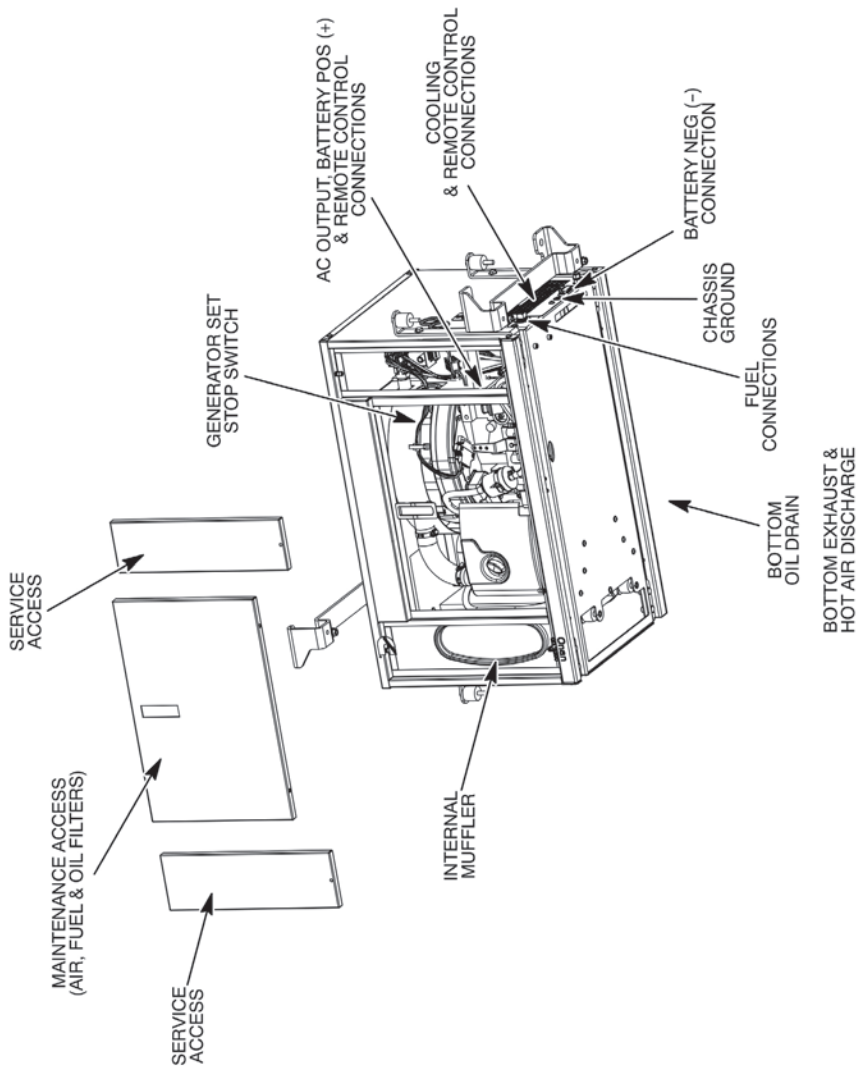

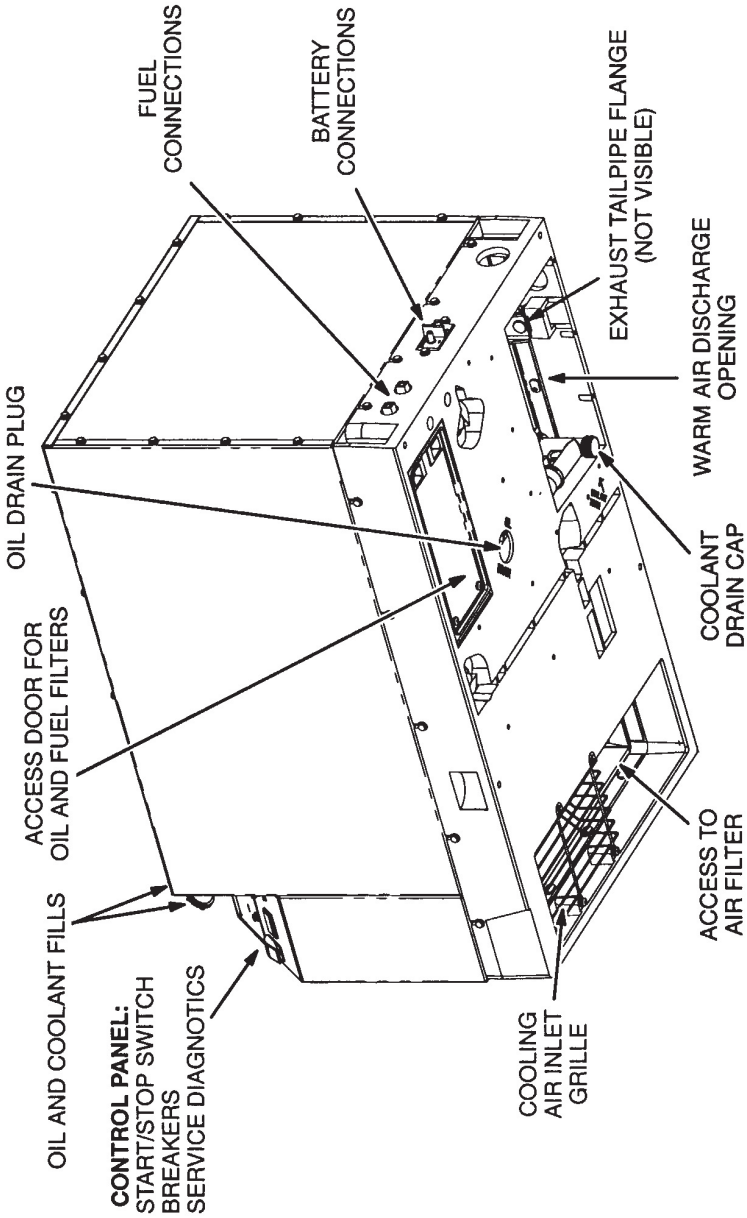

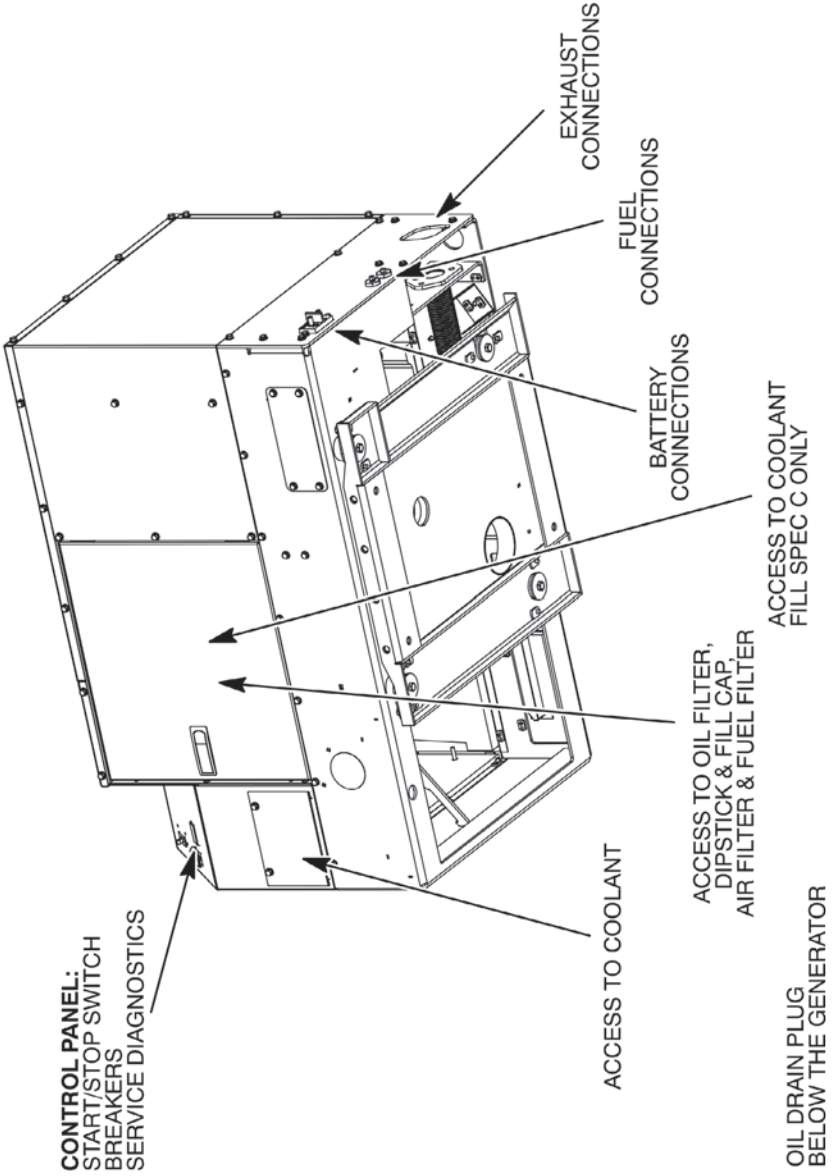

---

**ONAN RV QG 2500 LP RM/2800 RM (KVD)**

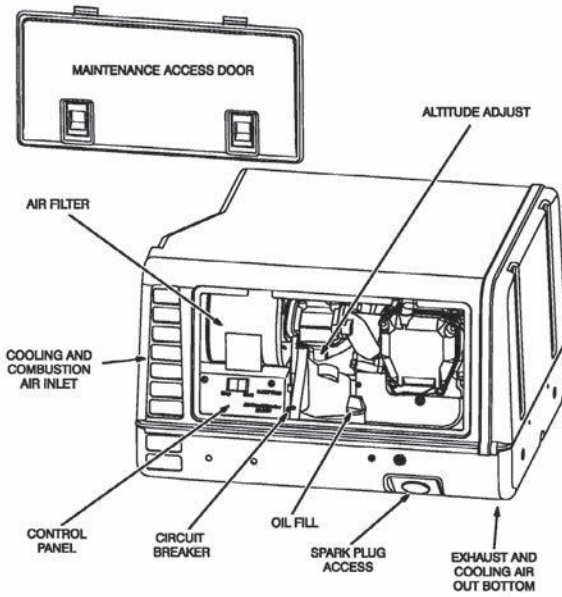

---

**ONAN RV QG 2500 LP/2800/2800 EVAP (KV)**

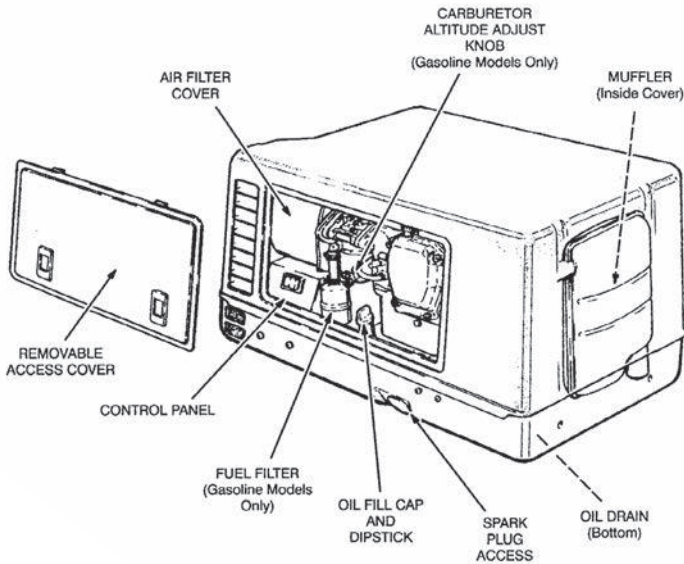



## BGE / NHE

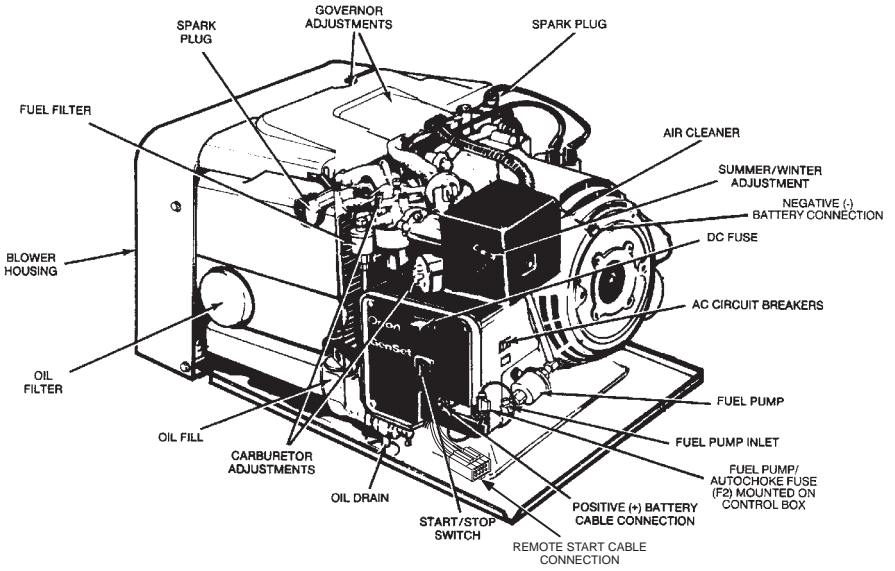

## MARQUIS™

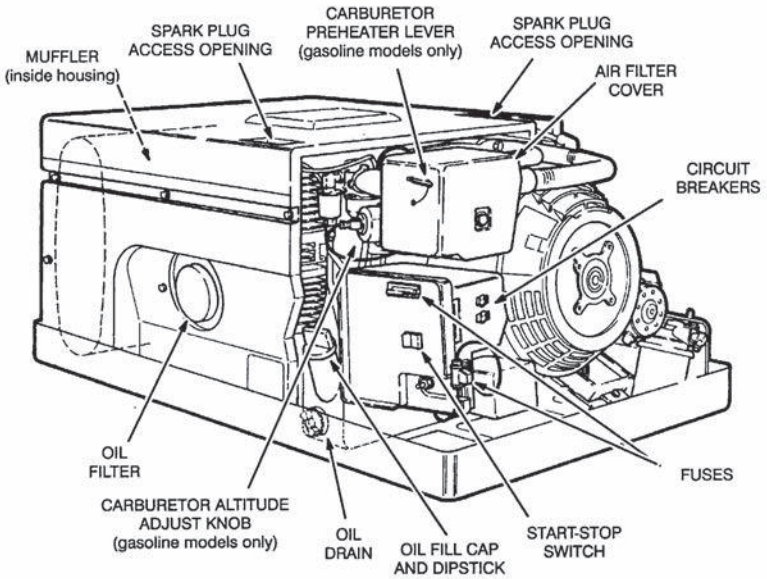

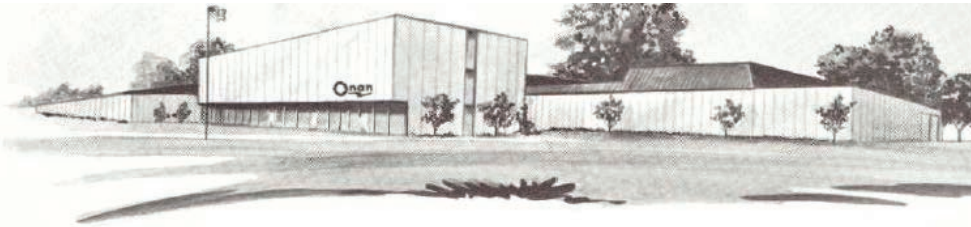

# ONAN

1400 73RD AVENUE N.E. • MINNEAPOLIS, MINNESOTA 55432  
A DIVISION OF ONAN CORPORATION

## 6 | GENERATOR MAINTENANCE: PARTS AND CHEMICALS

### INSIST ON THE QUALITY OF GREEN LABEL PARTS

Green Label replacement and maintenance products have been specially designed for Cummins RV generator use to provide you with dependable power and performance for the life of your generator. They are available from all Cummins authorized RV service and parts dealers.

You can also order maintenance parts online at [shopcummins.com](http://shopcummins.com) (for orders within the U.S.) or [shopcummins.ca](http://shopcummins.ca) (for orders within Canada). See pages 51–55 for part numbers by set.



## MAINTENANCE KITS

Maintenance kits are available for most of our current Onan RV Generator Diesel, Gas and LP models. These kits offer an exceptional value and provide you with everything needed to perform your regular maintenance. Each maintenance kit includes the necessary components to do the basic maintenance for your specific generator. These components may include:

- OnaMax oil
- Air, fuel and oil filter
- Spark plug(s)

Maintenance Kit part numbers:

A049E501 HGJAB — Gas	A049E506 HGJAB — LP
A050E991 KY — Gas	A050E993 KY — LP
A060Z347 HGJBB — Gas	A060Z345 KY 50Hz — Gas
A060Z227 HDKAK — Diesel	A060Z229 HDKCA — Diesel
A060Z222 HDKBB — Diesel	A060Z343 HGJAD — Gas

## AIR FILTERS

Green Label Parts are designed specifically for use in Cummins RV generators. Other manufacturers' air filters may contain a lighter density filter paper, and the sealing surfaces may get brittle and crack over time, allowing dirty air into the engine intake system. Over time, it only takes about a thimbleful of dirt to wear out piston rings and cylinders.

## SPARK PLUGS

The use of Green Label, resistive, original equipment spark plugs will keep your Cummins genset working properly. Use of other non-resistive plugs can cause generator shutdowns without fault codes.

## OIL FILTERS

Green Label Parts oil filters feature valves that allow oil to bypass the oil filter during cold starts or if the filter becomes plugged. Other manufacturers' oil filters often do not have bypass valves. As these "will-fit" filters trap debris, oil pressure starvation can occur, leading to high oil pressures, failed gaskets and even engine damage. Other "will-fit" oil filters may contain a bypass valve, but it's not possible to determine at what PSI the valve opens. If the setting is too high, the filter's paper element can be damaged during a cold start, rendering it useless, or cause oil starvation to the engine.

## FUSE PACK KIT

Pack of five fuses for use in most Cummins RV generators. Part #0541-1330.

## OIL FILTER WRENCH

Cup-type for easy removal of Cummins RV generator oil filters. Part #420-0577. The 420-0577 only fits the 122-0836 (5.5–7 QG) filter. The 420-0559 fits the older BG and NH product 122-0645 and 122-0800 oil filters.

**IMPORTANT: Cummins warrants only the quality and integrity of Green Label Parts. Any damage caused by the use of non-Green Label Parts filters will not be covered under the Cummins limited warranty.**

## USE CUMMINS OIL AND SERVICE / MAINTENANCE CHEMICALS TO ENSURE PERFORMANCE

### ONAMAX™ 15W-40 OIL AND 10W-30 OIL

Factory recommended and tested. Maximum protection engine oil formulated to reduce consumption and engine wear due to high-temperature oil oxidation and viscosity increase. Each 32 oz. bottle can be used on diesel or gas generators. This is the only oil targeted to the RV industry to work on either a diesel or gas engine. All others only work on one or the other.



15W-40 #326-5336 (preferred oil for diesel engines)  
10W-30 #A063E183 (preferred oil for gasoline engines)\*

\*Available early 2020

### ONAFRESH™ GXLP FUEL STABILIZER

A premium fuel additive specially formulated for long-lasting prevention of gasoline breakdown during extended RV storage. Protects gasoline against gum, varnish and sludge formation and fuel system corrosion. 16 oz. bottle treats 40 gallons of gasoline. #326-5365

### ONAGARD™ STORAGE FOGGING SPRAY

Protects small engines and other mechanical equipment during off-season storage. Provides protection for up to six months. 12 oz. aerosol can. #326-5288

When reliability counts, insist on Green Label Parts. Genuine Cummins.

Brand Name Model/Series	Spec Letter	Tune-up Kit	Oil Filter	Air Filter	Fuel Filter	Glow Plug or Spark Plug	Plug Wire
Cummins RV QG 2800 Series, RV QG 4000 Series, Camp Power, Onan MicroLite, Onan MicroQuiet™							
KVD	A-C	Electronic Ignition	●	140-2105 <sup>C</sup>	149-2137 <sup>H</sup>	167-0263-02 <sup>H</sup>	●
KV	A-M	Electronic Ignition	●	140-2105 <sup>C</sup>	149-2137 <sup>I</sup>	167-0263-02 <sup>I</sup>	●
KVC	A-C, F	Electronic Ignition	●	140-2105 <sup>C</sup>	149-2137 <sup>H</sup>	167-0263-02 <sup>H</sup>	●
HGJBB	A-B	Electronic Ignition	●	A030Y328 <sup>E</sup>	149-2661 <sup>I</sup>	167-1652 <sup>I</sup>	●
KY 50 Hz	A-H	Electronic Ignition	●	140-3280 <sup>E</sup>	149-2457 <sup>I</sup>	167-0305 <sup>I</sup>	●
KY 60 Hz	A B-H	Electronic Ignition	●	140-2609 <sup>E</sup> 140-3280 <sup>E</sup>	149-2457 <sup>I</sup>	167-0275 <sup>I</sup>	●
KY 50 Hz KY 60 Hz	J-R	Electronic Ignition	●	140-3280 <sup>C</sup>	149-2457 <sup>H</sup> 149-0275 <sup>H</sup>	167-0305 <sup>H</sup>	●
Cummins Onan RV QG 5500 Series, RV QG 7000 Series, Emerald Advantage, Onan Marquis Gold, Onan Marquis Platinum							
Carb - HGJAC LP Liquid/HGJAC LP Vapor/HGJAC	A-K	Electronic Ignition	122-0836 <sup>C</sup>	140-3116 <sup>C</sup>	*See note below <sup>H</sup> 149-2648 <sup>H</sup>	167-1638 <sup>H</sup>	●
Carb - HGJAB LP Liquid/HGJAB LP Vapor/HGJAB	A-L	Electronic Ignition	122-0836 <sup>C</sup>	140-3116 <sup>C</sup>	*See note below <sup>H</sup> 149-2648 <sup>H</sup>	167-1638 <sup>H</sup>	●
EFI/HGJAA LP Liquid/HGJAA LP Vapor/HGJAA	A-L	Electronic Ignition	122-0836 <sup>C</sup>	140-3116 <sup>C</sup>	541-1442 <sup>H,J</sup> 149-2648 <sup>H</sup>	167-1638 <sup>H</sup>	●

\* At fuel pump use 149-2341-01; At carb replace filter with A0295253 adaptor

Brand Name Model/Series	Spec Letter	Tune-up Kit	Oil Filter	Air Filter	Fuel Filter	Glow Plug or Spark Plug	Plug Wire
Cummins Onan RV QD 3200 Series, RV QD 6000/8000 Series, RV QD 10000/12500 Series							
HDKAH	A-K L-P	●	122-0833 <sup>C</sup>	140-2897 <sup>I</sup>	149-2513 <sup>I</sup> 541-1442 <sup>I</sup>	185-5421	●
HDKAK	A-K L-P	●	122-0833 <sup>C</sup>	140-2897 <sup>I</sup>	149-2513 <sup>I</sup> 147-0860 <sup>I</sup>	185-5421	●
HDKCA/CB	A-F G-H	●	122-0893 <sup>E</sup>	140-3071 <sup>I</sup>	149-2513 <sup>I</sup>	185-5990 A047D863	●
HDZAA	A-E	●	Clean every 1000 hrs	140-4151 <sup>I</sup>	149-2834 <sup>I</sup>	●	●
Onan HQD Series							
HQDPA	A-C	●	122-0833 <sup>C</sup>	140-2897 <sup>I</sup>	541-1442 <sup>I</sup>	185-5421	●
HQDPB	A B	●	185-5835 <sup>C</sup>	140-3071 <sup>I</sup>	541-1442 <sup>I</sup>	185-5421 333-0802	●
HQDPC	C	●	122-0833 <sup>C</sup>	140-2897 <sup>I</sup>	541-1442 <sup>I</sup>	185-5421	●
Onan Emerald™							
BGE	A-E F	160-1378	122-0645 <sup>C</sup>	140-2379 <sup>C</sup>	● 149-2279 <sup>F</sup>	167-0272 <sup>C</sup>	9" 167-1615-01 26" 167-1602
BGE	G H J-P	Electronic Ignition	122-0645 <sup>C</sup>	140-2379 <sup>F</sup>	149-2279 <sup>I</sup> 149-1353 <sup>I</sup> 149-2333 <sup>I</sup>	167-0272 <sup>I</sup>	9" 167-1615-01 26" 167-1602

Brand Name Model/Series	Spec Letter	Tune-up Kit	Oil Filter	Air Filter	Fuel Filter	Glow Plug or Spark Plug	Plug Wire
Emerald or Older							
BGEL	A-E	160-1378	122-0645 <sup>c</sup>	140-2379 <sup>c</sup>	148-0898 <sup>c</sup>	167-0272 <sup>c</sup>	9" 167-1615-01 26" 167-1602
NHE	A-E	160-1378	122-0800 <sup>c</sup>	140-2379 <sup>c</sup>	●	167-0272 <sup>c</sup>	9" 167-1615-01 26 " 167-1602
Prior to 9/87 NHE Begin 9/87 NHE	F	160-1349-01	122-0800 <sup>c</sup>	140-2379 <sup>F</sup>	149-2279 <sup>F</sup>	167-0272 <sup>i</sup>	160-1378
NHE	G H J-P	Electronic Ignition	122-0800 <sup>c</sup>	140-2379 <sup>F</sup>	149-2279 <sup>i</sup> 149-1353 <sup>i</sup> 149-2333 <sup>i</sup>	167-0272 <sup>i</sup>	9" 167-1615-01 26" 167-1602
NHEL Prior to 9/87 NHEL Begin 9/87 NHEL	A-E F	160-1378 160-1378 160-1349-01	122-0800 <sup>c</sup> 122-0645 <sup>c</sup>	140-2379 <sup>F</sup> 140-2379 <sup>F</sup>	148-0898 <sup>i</sup> 149-2279 <sup>i</sup>	167-0272 <sup>i</sup> 167-0272 <sup>i</sup>	9" 167-1615-01 9" 167-1615-01 26" 167-1602
Onan Marquis™							
Gasoline/BMG	A-F G-H	Electronic Ignition	122-0645 <sup>c</sup>	140-2379 <sup>c</sup>	149-2279 <sup>i</sup> 149-2341	167-0272 <sup>i</sup>	9" 167-1625-01 23" 167-1625-02
Gasoline/NHM	A-F G-H	Electronic Ignition	122-0800 <sup>c</sup>	140-2379 <sup>c</sup>	149-2279 <sup>i</sup> 149-2341	167-0272 <sup>i</sup>	23" 167-1602
LP/NHM	All	Electronic Ignition	122-0800 <sup>c</sup>	140-2379 <sup>c</sup>	148-0898 <sup>i</sup>	167-0272 <sup>g</sup>	23" 167-1602

Brand Name Model/Series	Spec Letter	Tune-up Kit	Oil Filter	Air Filter	Fuel Filter	Glow Plug or Spark Plug	Plug Wire
<b>Older Onan Generators</b>							
BF Power Drawer	A	312-0069	122-0645 <sup>D</sup>	140-1220 <sup>D</sup>	●	167-0262 <sup>B</sup>	167-1616-01
BF RV	A-B	●	●	140-0495 <sup>D</sup>	●	167-0237 <sup>B</sup>	167-1602
BFA RV	A B-D	●	122-0645 <sup>C</sup>	140-0495 Clean every 150 hrs	●	167-0237 <sup>C</sup> 167-0298 <sup>C</sup>	167-1602
BGA RV	A B-D	●	122-0645 <sup>B</sup>	140-0495 <sup>D</sup>	●	167-0237 <sup>B</sup> 167-0298 <sup>B</sup>	167-1602
BGAL RV	C	●	122-0645 <sup>B</sup>	140-0495 <sup>D</sup>	●	167-0298 <sup>B</sup>	167-1602
CCK Mobile/RV	A-Q R-U	●	122-0800 <sup>A,D</sup>	● 140-0495 <sup>D</sup>	●	167-0237 <sup>B</sup>	167-1602
LK RV	A-L M	●	●	● 140-1220 <sup>D</sup>	● 149-1353 <sup>G</sup>	167-0237 <sup>D</sup>	●
NH Power Drawer	A	312-0069	122-0800 <sup>A,B</sup>	140-1229 <sup>D</sup>	●	167-0262 <sup>D</sup>	167-1616-01
NH Power Drawer 9000	A-H	312-0069	122-0800 <sup>A,B</sup>	140-1229 <sup>D</sup>	●	167-0262 <sup>D</sup>	167-1616-01
NH RV	A-H J-N P-R	●	122-0800 <sup>A,B</sup>	140-0495 <sup>D</sup>	167-0241 <sup>D</sup> ● 167-0272 <sup>D</sup>	167-0247 <sup>D</sup>	167-1616-01
NHL	P	●	122-800 <sup>B</sup>	140-0495 <sup>D</sup>	●	167-0272 <sup>B</sup>	9" 167-1615-01 26" 167-1602



Spec Letter	Tune-up Kit	Oil Filter	Air Filter	Fuel Filter	Glow Plug or Spark Plug	Plug Wire
<b>Older Onan Diesel Generators</b>						
HDKAG	A-B				185-6623	
	C	●	185-5835 <sup>B</sup>	140-2842 <sup>I</sup>	A026K278 <sup>E</sup>	●
	D-F				185-5421	
	G				333-0805	
DKC RV	●	122-0827 <sup>B</sup>	140-2842 <sup>I</sup>	149-1914-05 <sup>E</sup>	185-2289	●
DKD RV	●	122-0827 <sup>B</sup>	140-2842 <sup>I</sup>	149-1914-05 <sup>E</sup>	185-2289	●
DKG	●	122-0827 <sup>B</sup>	140-2680 <sup>I</sup>	A026K278 <sup>E</sup>	185-2289	●
HDCAA/AB	●	187-1000 <sup>E</sup>	140-3071 <sup>I</sup>	149-2513 <sup>I</sup>	187-1289	●
HDKAJ	●	122-0833 <sup>C</sup>	140-2897 <sup>I</sup>	149-2513 <sup>I</sup> 541-1442 <sup>J</sup>	185-5421	●
HDKBA	●	122-0833 <sup>C</sup>	140-3351	149-2513 <sup>I</sup>	185-5421	●

#### NOTES

- Interval recommendations assume oil changes are after initial break-in.
- If fewer than the recommended hours, then change annually.
- Change more often in dirty and dusty conditions. Please refer to your operator's manual for more detail.
- If required.
- If discrepancy between the guide and your operator's manual, the operator's manual wins.

#### Maintenance intervals

- |              |              |              |                                      |
|--------------|--------------|--------------|--------------------------------------|
| A. 50 hours  | D. 200 hours | G. 400 hours | J. 541-1442 Fuel Filter kit includes |
| B. 100 hours | E. 250 hours | H. 450 hours | 147-0860 Fuel Filter and two         |
| C. 150 hours | F. 300 hours | I. 500 hours | 503-2808 screw drive clamps.         |



## 7 | WARRANTY AND SERVICE

### **STANDARD THREE-YEAR LIMITED WARRANTY WITH AVAILABLE FIVE-YEAR EXTENDED COVERAGE**

We're so confident in our RV generators, we back them with a standard three-year limited warranty—the longest, most comprehensive warranty in the business. In order to receive the latest updates for your generator, please go to [now.cummins.com/product-registration-consumer](https://www.cummins.com/product-registration-consumer) and fill out the registration form. Coverage is transferable from one owner to another if you sell your RV during the generator warranty period.

### **LARGEST AUTHORIZED SERVICE AND PARTS DEALER NETWORK IN THE INDUSTRY**

Wherever you travel, Cummins authorized RV service and parts dealers are never far away. Authorized dealers trained and tested in all aspects of generator operation and maintenance cover every major market in the United States and Canada. Cummins extensive training and certification process demonstrates our strong commitment to exceptional product service and support. Find a list of Cummins authorized RV service dealers in the United States and Canada by visiting [locator.cummins.com](https://locator.cummins.com).

For Onan RV generators, warranty commences with the sale to the first retail purchaser. Your bill of sale is your proof of the start date. If the RV was used by a dealer or OEM as a demo unit, warranty would start once the generator reaches 100 hours of operation or with the first retail purchase of the RV. Whichever comes first.

# AUTO GENERATOR START CONTROL SYSTEM

Cummins Energy Command is a low-cost, high-value enhancement that provides the following benefits to the RV owner:



## ENERGY MANAGEMENT

- Turns on the generator to meet air conditioning demands
- Look-ahead battery top-off feature prior to “quiet time”
- Monitors battery levels and starts the generator to provide power to the converter for battery charging
- Computes battery status from historical and anticipated battery performance
- Anticipates changes in usage to minimize both run time and start/stop cycling for less wear and tear on the generator

## SERVICE INFORMATION

- Displays generator service maintenance reminders and diagnostic text messages for easy troubleshooting

## ENHANCED SAFETY

- Safety start inhibits automatic generator starting in unsafe conditions

## OTHER FEATURES INCLUDE:

- Digital generator hour meter
- Start/stop switch with digital readout
- Auto start/stop on low/full battery
- Auto start/stop for up to three air conditioning systems
- Built-in memory for all programmable settings
- House battery bank state of charge gauge
- House battery bank voltage
- Engine battery bank voltage

*NOTE: This product is typically an OEM installed option.*

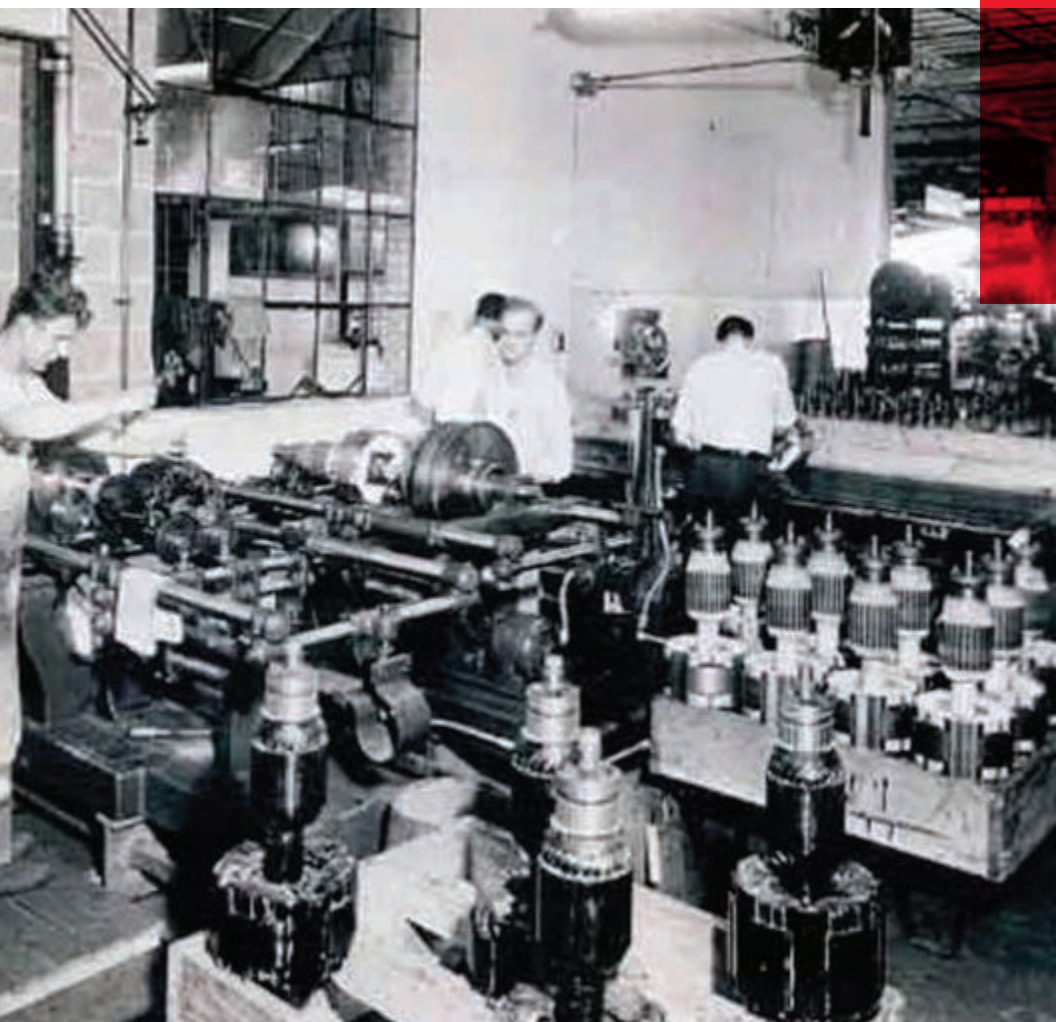

## **8 | CURRENT RV GENERATOR MODEL INFORMATION**



# QUIET GAS

Built to deliver quiet, reliable power for sport utility trailers, fifth-wheels and Type A, B and C RVs, the Quiet Gas models from Cummins are the most popular in RVing. Besides carbureted gasoline and LP units, electronic fuel-injected gasoline models are also available.

QG 2800  
QG 2500 LP



QG 4000  
QG 3600 LP



GENERATOR RATINGS		
Hertz	60	60
Watts	2,800 (2,500)	4,000 (3,600)
RPM	3,600	3,600
Volts	120	120
Amps	23.3 (20.8)	33.3 (30)
Weight	125 lbs	176 lbs
DIMENSIONS		
LxWxH – inches	22x16.3x12.8	30x19.7x14.4
AVERAGE FUEL CONSUMPTION		
No load	0.2 Gal/h (1.2 lb/h)	0.3 Gal/h (1.5 lb/h)
Half load	0.4 Gal/h (1.6 lb/h)	0.5 Gal/h (2.4 lb/h)
Full load	0.5 Gal/h (2.3 lb/h)	0.7 Gal/h (3.1 lb/h)
PERFORMANCE – 100 °F/38 °C AND 500 FT/152.4 M ALTITUDE		
Air conditioner (BTU)	One 13,500 (HE)*	One 15,000
Additional watts available	300 (0)	1,100 (700)
Battery charger	600	600
ENGINE DETAIL		
Number of cylinders/type	1/OHC	1/OHV
Cooling system	Air	Air
SOUND LEVEL – 10 FT/3 M		
Half load†	72 dBA	68 dBA

\* HE – High-efficiency air conditioner required.

† Actual sound level may vary based on product installation and environmental conditions.

QG 5500  
QG 5500 LP



QG 5500 EFI



QG 7000  
QG 6500 LP



QG 7000 EFI



60	60	60	60
5,500	5,500	7,000 (6,500)	7,000
2,400	2,400	2,880	2,880
120	120	120	120
45.8	45.8	58.3 (54.2)	58.3
279 lbs	279 lbs	290 lbs	290 lbs
33.6x22.2x16.7	33.6x22.2x16.7	33.6x22.2x16.7	33.6x22.2x16.7
0.3 Gal/h (1.8 lb/h)	0.3 Gal/h	0.4 Gal/h (2.2 lb/h)	0.4 Gal/h
0.6 Gal/h (3.3 lb/h)	0.6 Gal/h	0.7 Gal/h (3.5 lb/h)	0.7 Gal/h
0.9 Gal/h (4.6 lb/h)	0.9 Gal/h	1.2 Gal/h (5.3 lb/h)	1.1 Gal/h
Two 15,000	Two 15,000	Two 15,000	Two 15,000
400 (400)	400	1,900 (1,400)	1,900
600	600	600	600
2/V-twin	2/V-twin	2/V-twin	2/V-twin
Air	Air	Air	Air
69 dBA	69 dBA	70 dBA	70 dBA

# QUIET DIESEL

So quiet and smooth, you won't believe they're diesels. Setting the standard for diesel RV generators, the Quiet Diesel™ Series dramatically lowers noise, vibration and harshness levels for diesel-powered RVs.

QD 3200



QD 6000



GENERATOR RATINGS		
Hertz	60	60
Watts	3,200	6,000
RPM	Constant	Variable
Volts	120	120
Amps	26.7	50
Weight	205 lbs	420 lbs
DIMENSIONS		
(LxWxH in inches)	30.2x17.3x18.0	36.3x23.6x22.3
AVERAGE FUEL CONSUMPTION		
No load	0.20 gal/h	0.13 gal/h
Half load	0.30 gal/h	0.40 gal/h
Full load	0.40 gal/h	0.70 gal/h
PERFORMANCE – 100 °F/38 °C AND 500 FT/152.4 M ALTITUDE		
Air conditioner (BTU)	One 13,500	Two 15,000
Additional watts available	500	300
Battery charger	500	1,200
ENGINE DETAIL		
Number of cylinders/type	1	3/inline
Cooling system	Air	Liquid
SOUND LEVEL @ 10 FT (3 M)		
Half load†	68 dBA	72 dBA

\* HE – High-efficiency air conditioner required.

\* Support for three 15,000 BTU AC on QD 8000X model version–requires application approval.

† Actual sound level may vary based on product installation and environmental conditions.



QD 8000



QD 10000



QD 12500



60	60	60
8,000	10,000	12,500
Variable	Constant	Constant
120	120/240	120/240
66.6	83.3/41.7	104.0/52.0
420 lbs	765 lbs	770 lbs
36.3x23.6x22.3	41.4x24.5x27.0	41.4x24.5x27.0
0.13 gal/h	0.11 gal/h	0.11 gal/h
0.49 gal/h	0.43 gal/h	0.48 gal/h
1.02 gal/h	1.0 gal/h	1.20 gal/h
Two 15,000*	Three 15,000	Three 15,000
1,800	2,100	3,800
1,200	1,200	1,200
3/inline	3/inline	3/inline
Liquid	Liquid	Liquid
66 dBA	68 dBA	69 dBA

# POWER THAT'S PORTABLE.

Cummins new advanced portable inverter and dual-fuel generators



## Onan P2500i

2500 Watt Digital Inverter  
Gasoline Portable Generator

- Built-in carry handle for easy transportation
- Parallel capable with another P2500i inverter generator
- Two 5V USB ports for charging sensitive electronics such as phones or tablets
- Rubber outlet dust covers
- Dependable 3.4 HP 98cc OHV 4-Stroke engine
- Rubber mat on top for storing electronic devices such as phones while charging
- 3-Year Warranty



## Onan P4500i

4500 Watt Digital Inverter  
Gasoline Portable Generator

- RV and camper ready with 30A TT-30R outlet
- Two 5V USB ports for charging sensitive electronics such as phones or tablets
- Rubber outlet dust covers
- Telescoping handle for easy transportation
- Dependable 7.3 HP 224cc OHV 4-Stroke engine
- Parallel capable with another P4500i inverter generator to reach 50A of power
- 3-Year Warranty



## Onan P9500df

9500 Watt Dual Fuel (Gas/LPG)  
Portable Generator

- Dependable 13 HP 420cc OHV 4-Stroke engine
- Fuel gauge on top of 6.6 gallon tank
- Battery charging port with charger included
- Rubber outlet dust covers
- 3-Year Warranty



# YOU DESERVE A DIESEL.

## THE CUMMINS ADVANTAGE FOR MOTORHOMES.

If you are choosing between a gasoline-powered RV and a diesel coach, there's more to consider than just the initial price. Comfort, driveability, towing capability, safety, durability, maintenance and resale value are all impacted by this decision. Owning a motorhome is about enjoying life and all that you've accomplished – you deserve a diesel!



### Torque And Driveability.

Compared with gas-powered RVs, diesel coaches:

- Deliver 50 percent more torque, for stronger uphill acceleration
- Allow you to tow boats, trailers or vehicles with confidence
- Deliver stronger performance without working as hard

### Braking And Safety.

The braking systems on diesel coaches provide drivers with greater confidence going downhill:

- Hydraulic anti-lock braking systems on gas-powered RVs don't provide the stopping power of air brakes on diesel pushers
- Most diesel coaches come with exhaust or engine brakes, for additional braking horsepower over that of normal service brakes; reduced service brake use minimizes the need for expensive brake jobs
- Reduced risk of glazing, overheating or fading increases safe control on steep downhill grades

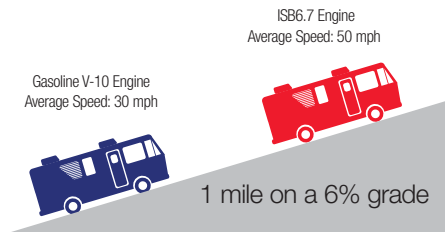



## COACH CARE

Cummins new and improved Coach Care™ now offers complete chassis and major systems service to provide trusted RV service near you.



**YOUR CHOICE OF TWO LEVELS OF RV AND MOTORHOME SERVICE CAPABILITY:**

**COACH CARE POWER**

Factory and chassis-certified technicians providing Cummins motorhome engine service + Cummins RV generator service + Spartan chassis + Related components

**COACH CARE COMPLETE**

Factory and chassis-certified technicians servicing: All the RV and motorhome engine, generator and chassis service of Coach Care Power, PLUS Major appliances + Heating and cooling systems + Electrical systems + Plumbing systems + LP system







**Cummins Inc.**  
**Box 3005**  
**Columbus, IN 47202-3005**  
**U.S.A.**

1-800-CUMMINS™ (1-800-286-6467)  
[power.cummins.com](http://power.cummins.com)

[Twitter.com/CumminsPowerGen](https://twitter.com/CumminsPowerGen)  
[YouTube.com/CumminsPowerGen](https://www.youtube.com/CumminsPowerGen)

Bulletin 5410860 (F-1123) Printed in U.S.A. Rev. 12/19  
©2019 Cummins Inc.