



**RECORD THIS INFORMATION FOR FUTURE REFERENCE:**

Model Number \_\_\_\_\_  
 Serial Number \_\_\_\_\_  
 ADB Model Number \_\_\_\_\_  
 ADB Serial Number \_\_\_\_\_  
 Date Purchased \_\_\_\_\_

# INSTALLATIONS INSTRUCTIONS

Roof Top Unit Used With 3105007.XXX OR 3105935.XXX Return Air Grille				
Description	Model	Board Built In	Thermostat	Optional Indoor Temperature Sensor
<b>Air Conditioner</b>				
CCC 2 Controls	641815 641816	Board Built In	3314082.000 CCC 2-Blk 3314082.011 CCC 2-Wht	3311931.000-20' 3311931.012-40' 3311931.020-60'
CCC 2 Controls W/Electric Heat	641835	Board Built In	3314082.000 CCC 2-Blk 3314082.011 CCC 2-Wht	3311931.000-20' 3311931.012-40' 3311931.020-60'
<b>Heat Pump</b>				
CCC 2 Controls	651815 651816	Board Built In	3314082.000 CCC 2-Blk 3314082.011 CCC 2-Wht	3311931.000-20' 3311931.012-40' 3311931.020-60'

This Unit is designed for OEM installation. All initial installations must be approved by Dometic Corporation



**Read these instructions carefully. These instructions MUST stay with this product.**

**REVISION D**  
 Form No. 3313461.018 8/18  
 (French 3313462.016\_D)  
 ©2018 Dometic Corporation  
 LaGrange, IN 46761

**USA**  
 SERVICE OFFICE  
 Dometic Corporation  
 1120 North Main Street  
 Elkhart, IN 46514

**SERVICE CENTER & DEALERLOCATIONS**  
**Please Visit:**  
[www.Dometic.com](http://www.Dometic.com)

# INTRODUCTION

This air conditioner/heat pump (hereinafter referred to as “unit” or “product”) is designed and intended for installation on the roof of a Recreational Vehicle (hereinafter referred to as RV) during the time it is manufactured.

This unit can be installed by one person with brief help from additional personnel. Use these instructions to ensure a properly installed, and properly functioning product.

Dometic Corporation reserves the right to modify appearances and specifications without notice.

# TABLE OF CONTENTS

INTRODUCTION .....	2
DOCUMENT SYMBOLS.....	2
IMPORTANT SAFETY INSTRUCTIONS .....	3
A. Recognize Safety Information .....	3
B. Understand Signal Words.....	3
C. Supplemental Directives.....	3
D. General Safety Messages .....	3
SPECIFICATIONS .....	4
A. Table - Unit Data.....	4
B. Roof Requirements.....	4
C. Table - Air Distribution Duct Sizing & Design.....	5
INSTALLATION INSTRUCTIONS .....	5
A. Choosing Proper Location For Unit .....	5
B. Roof Preparation .....	6
C. Air Distribution Duct Sizing & Design .....	7
D. Wiring Requirements.....	8
E. Choosing Thermostat Locations.....	8
F. Thermostat, Optional Indoor Temperature Sensor & Thermostat Communication Cable Installation.....	8
G. Placing Unit On Roof.....	10
H. Installing Unit.....	10
I. Wiring System .....	12
J. System Configuration .....	12
K. Installing Return Air Cover.....	13
L. System Reset & Checkout.....	14
M. Furnace /Aqua Temperature Differential Setting .....	14
GENERAL INFORMATION .....	15
A. Frost Formation On Cooling Coil.....	15
B. Condensation .....	15
C. Air Distribution .....	15
WIRING DIAGRAMS .....	16
A. Simple RV Wiring Diagram.....	16
B. Unit Wiring Diagrams.....	17

# DOCUMENT SYMBOLS

 Indicates additional information that is **NOT** related to physical injury.

 Indicates step-by-step instructions.

# IMPORTANT SAFETY INSTRUCTIONS

This manual has safety information and instructions to help you eliminate or reduce the risk of accidents and injuries.

## A. Recognize Safety Information



This is the safety alert symbol. It is used to alert you to potential physical injury hazards. Obey all safety messages that follow this symbol to avoid possible injury or death.

## B. Understand Signal Words

A signal word will identify safety messages and property damage messages, and will indicate the degree or level of hazard seriousness.

**WARNING** indicates a hazardous situation that, if **NOT** avoided, could result in death or serious injury.

**CAUTION** indicates a hazardous situation that, if **NOT** avoided, could result in minor or moderate injury.

**NOTICE** is used to address practices **NOT** related to physical injury.

## C. Supplemental Directives



Read and follow all safety information and instructions to avoid possible injury or death.

Read and understand these instructions before [installing / using / servicing / performing maintenance on] this product.

Incorrect [installation / operation / servicing / maintaining] of this product can lead to serious injury. Follow all instructions.



The installation **MUST** comply with all applicable local and national codes, including the latest edition of the following standards:

### U.S.A.

- ANSI/NFPA70, National Electrical Code (NEC)
- ANSI/NFPA 1192, Recreational Vehicles Code

### CANADA

- CSA C22.1, Parts I & II, Canadian Electrical Code
- CSA Z240 RV Series, Recreational Vehicles

## D. General Safety Messages



Failure to obey the following warnings could result in death or injury:

- This product **MUST** be [installed / serviced] by a qualified service technician.
- Do **NOT** modify this product in any way. Modification can be extremely hazardous.
- Do **NOT** add any devices or accessories to this product except those specifically authorized in writing by Dometic Corporation.

# SPECIFICATIONS

## A. Table - Unit Data

Model No.	Nominal Capacity (BTU HR) Cooling	Electrical Rating	Compressor Rated Load Amps	Compressor Locked Rotor Amps	Fan Motor Rated Load Amps	Fan Motor Locked Rotor Amps	Refrigerant R-410A (oz)	Minimum Wire Size*	AC Circuit Protection ***Installer Supplied	Minimum Generator Size** 1 Unit / 2 Units
641815.30X	13,500	120 Vac 60 Hz 1 ph	12.5	61.0	3.5	10.0	17.5	12 AWG Copper Up to 24'	20 Amp	3.5 kW / 5.0 kW
641815C35X	13,500		12.5	61.0	3.5	10.0	17.5		20 Amp	3.5 kW / 5.0 kW
641815C75X	13,500		12.7	52.0	2.6	8.5	14.5		20 Amp	3.5 kW / 5.0 kW
641815H75X	13,500		12.7	52.0	2.6	8.5	14.5		20 Amp	3.5 kW / 5.0 kW
641815.80X	13,500		12.6	63.0	2.6	8.5	19.0		20 Amp	3.5 kW / 5.0 kW
641815C85X	13,500		12.6	63.0	2.6	8.5	19.0		20 Amp	3.5 kW / 5.0 kW
641815H85X	13,500		12.6	63.0	2.6	8.5	19.0		20 Amp	3.5 kW / 5.0 kW
641816.30X	Hi Cap		12.3	61.0	3.3	8.5	23.0		20 Amp	3.5 kW / 5.0 kW
641816C35X	Hi Cap		12.6	61.0	3.3	8.5	23.0		20 Amp	3.5 kW / 5.0 kW
641816C75X	Hi Cap		12.9	52.0	2.6	8.5	21.5		20 Amp	3.5 kW / 5.0 kW
641816H75X	Hi Cap		12.9	52.0	2.6	8.5	21.5		20 Amp	3.5 kW / 5.0 kW
641816.80X	Hi Cap		13.4	63.0	2.6	8.5	23.0		20 Amp	3.5 kW / 5.0 kW
641816C85X	Hi Cap		13.4	63.0	2.6	8.5	23.0		20 Amp	3.5 kW / 5.0 kW
641816H85X	Hi Cap		13.4	63.0	2.6	8.5	23.0		20 Amp	3.5 kW / 5.0 kW
641835.30X	13,500		12.5	61.0	3.5	10.0	17.5		20 Amp	3.5 kW / 5.0 kW
641835.35X	13,500		12.5	61.0	3.5	10.0	17.5		20 Amp	3.5 kW / 5.0 kW
641835C35X	13,500		12.5	61.0	3.5	10.0	17.5		20 Amp	3.5 kW / 5.0 kW
641835C75X	13,500		12.7	52.0	2.6	8.5	14.5		20 Amp	3.5 kW / 5.0 kW
641835H75X	13,500		12.7	52.0	2.6	8.5	14.5		20 Amp	3.5 kW / 5.0 kW
641835.80X	13,500		12.6	63.0	2.6	8.5	19.0		20 Amp	3.5 kW / 5.0 kW
641835C85X	13,500		12.6	63.0	2.6	8.5	19.0		20 Amp	3.5 kW / 5.0 kW
641835H85X	13,500		12.6	63.0	2.6	8.5	19.0		20 Amp	3.5 kW / 5.0 kW
651815.30X	13,500		12.5	61.0	3.5	10.0	25.0		20 Amp	3.5 kW / 5.0 kW
651815C35X	13,500		12.5	61.0	3.5	10.0	25.0		20 Amp	3.5 kW / 5.0 kW
651815C75X	13,500		12.7	52.0	2.6	8.5	19		20 Amp	3.5 kW / 5.0 kW
651815H75X	13,500		12.7	52.0	2.6	8.5	19		20 Amp	3.5 kW / 5.0 kW
641815.80X	13,500		13.1	63.0	2.6	8.5	24.0		20 Amp	3.5 kW / 5.0 kW
651815C85X	13,500	13.1	63.0	2.6	8.5	24.0	20 Amp	3.5 kW / 5.0 kW		
651815H85X	13,500	13.1	63.0	2.6	8.5	24.0	20 Amp	3.5 kW / 5.0 kW		
651816.30X	Hi Cap	12.3	61.0	3.3	8.5	24.0	20 Amp	3.5 kW / 5.0 kW		
651816C35X	Hi Cap	12.3	61.0	3.3	8.5	24.0	20 Amp	3.5 kW / 5.0 kW		
651816C75X	Hi Cap	13.0	52.0	2.6	8.5	22.0	20 Amp	3.5 kW / 5.0 kW		
651816H75X	Hi Cap	13.0	52.0	2.6	8.5	22.0	20 Amp	3.5 kW / 5.0 kW		
651816.80X	Hi Cap	13.4	63.0	2.6	8.5	27.0	20 Amp	3.5 kW / 5.0 kW		
651816C85X	Hi Cap	13.4	63.0	2.6	8.5	27.0	20 Amp	3.5 kW / 5.0 kW		
651816H85X	Hi Cap	13.4	63.0	2.6	8.5	27.0	20 Amp	3.5 kW / 5.0 kW		

\* For wire length over 24 ft., consult the National Electrical Code for proper sizing.

\*\* Dometic Corporation gives **GENERAL** guidelines for generator requirements. These guidelines come from experiences people have had in actual applications. When sizing the generator, the total power usage of your RV must be considered. Keep in mind generators lose power at high altitudes and from lack of maintenance.

\*\*\* CIRCUIT PROTECTION: Time Delay Fuse or Circuit Breaker Required.

## B. Roof Requirements

- A 14-1/4" x 14-1/4" (±1/8") square opening (hereinafter referred to as "roof opening") is required for installing this unit. This opening is part of the return air system of the unit and **MUST** be finished in accordance with NFPA 1192.
- Roof construction with rafters/joists support frames on a minimum of 16 inch centers.
- Minimum of 2 inches and maximum of 5-1/2 inches distance between roof to ceiling of RV.

# SPECIFICATIONS

## C. Table - Air Distribution Duct Sizing & Design

	<b>Return Air Grille Kit</b> 3105007.XXX 3105935.XXX
<b>Roof Cavity Depth</b>	2.0 In. Min. - 5-1/2 In. Max.
<b>Duct Cross Sectional Area</b>	21.0 Sq. In. Min.
<b>Duct Size</b> Depth Width Total Duct Length Duct Length (short run)	1-1/2 In. Min. - 2-1/2 In. Max. 7.0 In. Min. - 10.0 In. Max. 15.0 Ft. Min. - 40.0 Ft. Max. 1/3 Total Duct Length
<b>Register Requirements per A/C Unit</b> Number Required Register Free Air Area Distance From Duct End Distance From Elbow	4 Min. - 8 Max. 14.0 Sq. In. 5.0 In. Min. - 8.0 In. Max. 15.0 In.
<b>Total System Static Air Pressure</b> Blower at High Speed, Filter & Grille In Place	0.12 - 0.65 In. W.C.

# INSTALLATION INSTRUCTIONS

## A. Choosing Proper Location For Unit

This unit is specifically designed for installation on the roof of an RV. When determining your cooling requirements, the following should be considered:

- Size of RV;
  - Window area (increases heat gain);
  - Amount of insulation in walls and roof;
  - Geographical location where the RV will be used;
  - Personal comfort level required.
1. For one unit installation: The unit should be mounted slightly forward of center (front to back) and centered from side to side.
  2. For two unit installations: Install one unit 1/3 and one unit 2/3's from front of RV and centered from side to side.

It is preferred that the unit be installed on a relatively flat and level roof section measured with the RV parked on a level surface. See table below for maximum acceptable tilt.

Model Number	Max Tilt
641815	8°
641816	
641835	
651815	
651816	

## 3. After Location Has Been Selected:

- a. Check for obstructions in the area where unit will be installed. See (FIG. 1) & (FIG. 2).

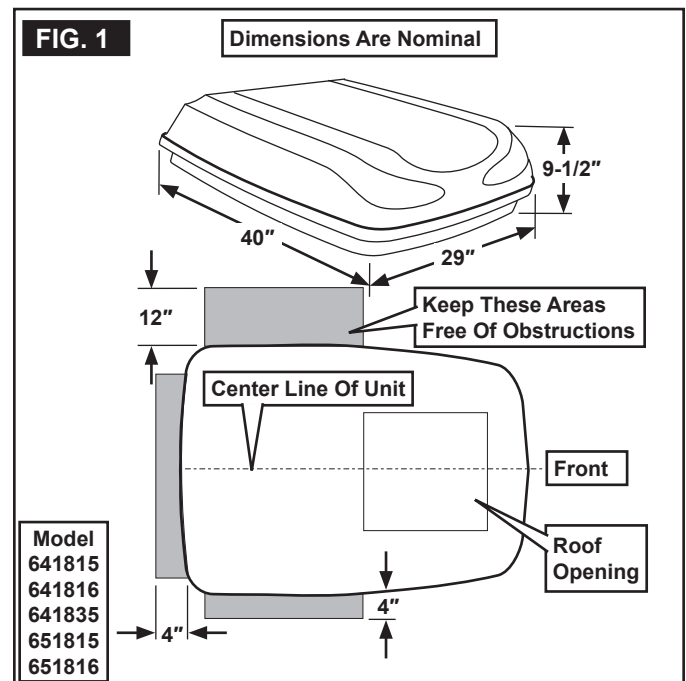

# INSTALLATION INSTRUCTIONS

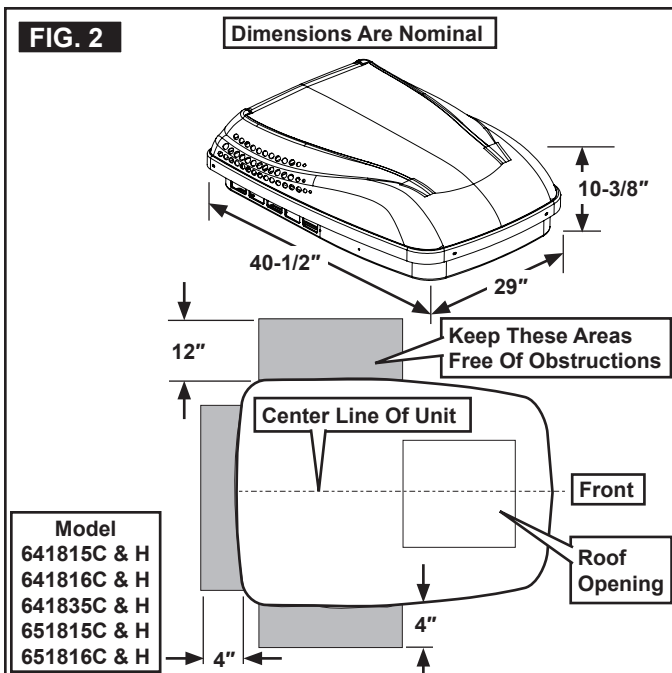

- b. **NOTICE** Maintain structural integrity. Otherwise damage to product and/or RV could occur.

The roof must be designed to support 130 pounds when RV is in motion. Normally a 200 lb. static load design will meet this requirement.

- c. Check inside the RV for return air grille (hereinafter referred to as "RAG") obstructions (i.e. door openings, room dividers, curtains, ceiling fixtures, etc). See (FIG. 3).

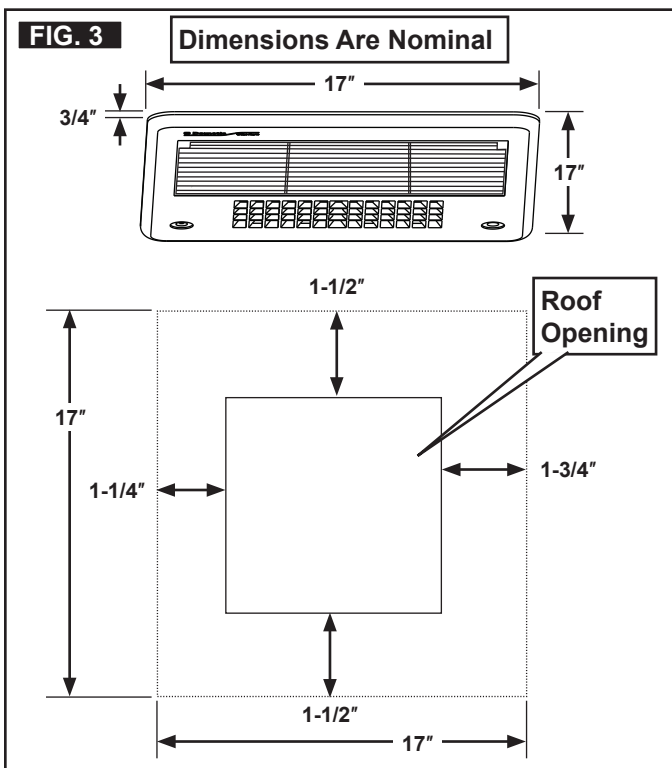

## B. Roof Preparation

1. **WARNING** FIRE OR ELECTRICAL SHOCK HAZARD. Make sure there are no obstacles (wires, pipes, etc.) inside RV's [roof / floor / walls]. Shut **OFF** gas supply, disconnect 120 Vac power from RV, and disconnect positive (+) 12 Vdc terminal from supply battery **BEFORE** drilling or cutting into RV. Failure to obey these warnings could result in death or serious injury.

**i** Opening Requirements - Before preparing the ceiling opening, the type of system options **MUST** be decided upon. Read all of the following instructions before beginning the installation.

2. Carefully mark and cut the required roof opening. See "B. Roof Requirements" on page (4).
3. Using the roof opening as a guide, cut the matching hole in the ceiling.
4. **NOTICE** Maintain structural integrity. Otherwise damage to product and/or RV could occur.
5. **NOTICE** NEVER create a low spot on RV roof. Otherwise, water will pool and could cause a leak.

The opening created must be framed to provide adequate support and prevent air from being drawn from the roof cavity. Framing stock 3/4" or more in thickness must be used. Remember to provide an entrance hole for power supplies, indoor temperature sensor (if applicable), thermostat communication cable, and furnace wires (if applicable) at the front of the opening. See (FIG. 4).

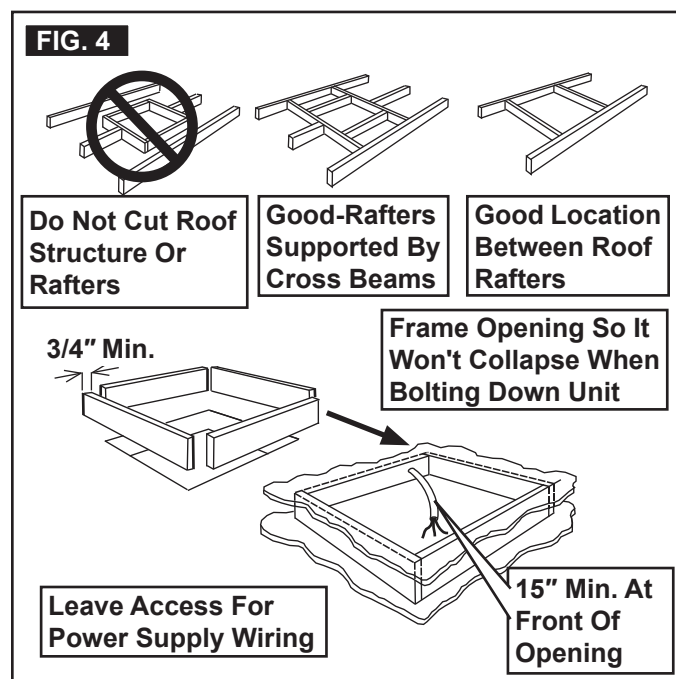

# INSTALLATION INSTRUCTIONS

## C. Air Distribution Duct Sizing & Design

The installer of this system must design the air distribution system for their particular application. Several requirements must be met for the unit to operate properly. These requirements are as follows:

1. **NOTICE** Make sure ductwork will **NOT** bend or collapse during and after installation, and that it is correctly insulated and sealed. Otherwise, damage to roof structure and ceiling could occur.
2. All discharge air ducts must be properly insulated to prevent condensation from forming on their surfaces or adjacent surfaces during operation of unit. This insulation must be R-7 minimum. See (FIG. 5).

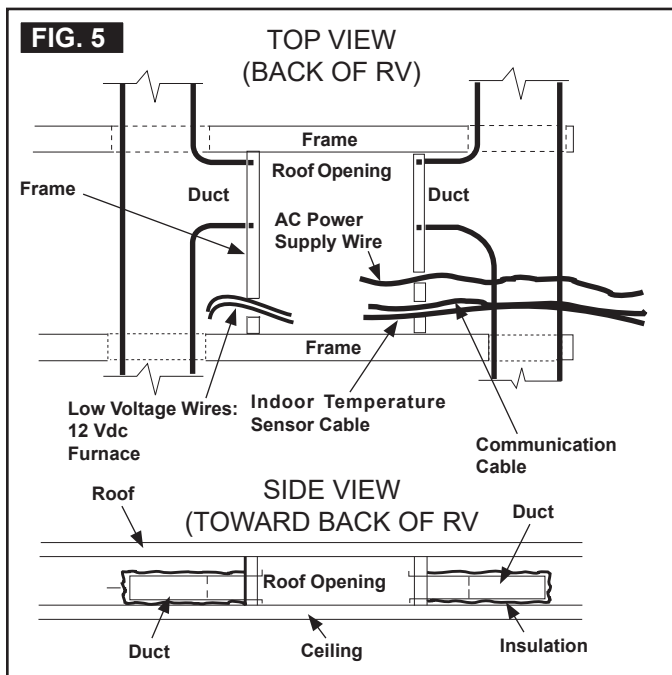

3. Ducts and their joints must be sealed to prevent condensation from forming on adjacent surfaces during operation of the unit.
4. Return air openings must have 40 square inches minimum free area including the filter.
5. Return air to the unit must be filtered to prevent dirt accumulation on unit cooling surface.
6. Air Distribution System Installation

- a. Dometic Corporation recommends the basic configuration shown in (FIG. 6), for installing this system. We have found by testing, that this configuration works best in most applications. It is the responsibility of the installer to review each RV floor plan to determine the following:

- Duct size
- Duct layout
- Register size
- Register location
- Thermostat location
- Indoor Temperature Sensor Location

These items must be determined in conjunction with the Air Distribution Duct System Sizing & Design requirements. See "C. Table - Air Distribution Duct Sizing & Design" on page (5).

**i** Alternate configurations and methods may be used which will allow the unit to operate properly; however, these alternate configurations and methods **MUST** be approved by Dometic Corporation in writing. The following instructions are based upon the use of RAG Kits 3105007.XXX & 3105935.XXX.

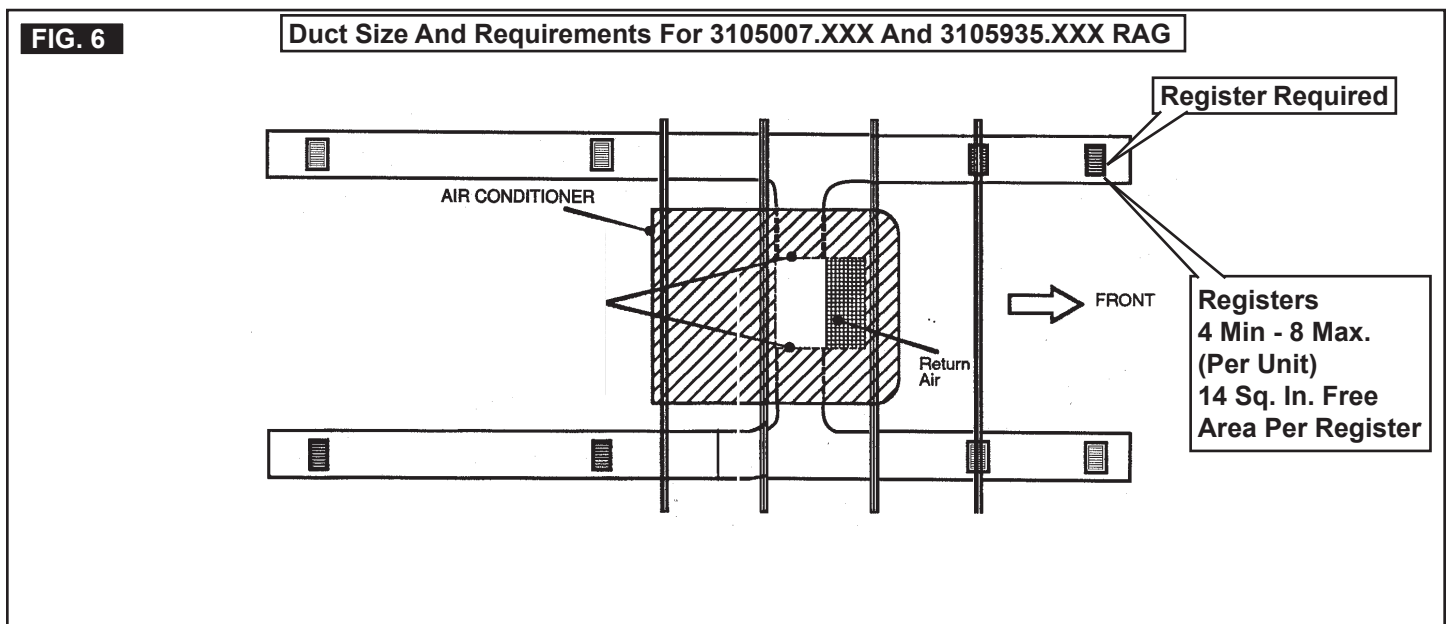





# INSTALLATION INSTRUCTIONS

## D. Wiring Requirements

1. Route a copper, with ground, 120 Vac supply wire from the time delay fuse or circuit breaker box to the roof opening. Use a listed/certified non metallic - sheathed single strand cable. See "A. Table - Unit Data" on page (4).
  - a. This supply wire must be located in the front portion of the roof opening.
  - b. The power **MUST** be on an appropriately sized separate time delay fuse or circuit breaker. See "A. Table - Unit Data" on page (4).
  - c. Make sure that at least 15" of supply wire extends into the roof opening This ensures an easy connection at the junction box.
  - d. Protect the wire where it passes into the opening with approved method.
2. Route a dedicated 12 Vdc supply wire (18-22 AWG) from the RV converter (filtered side) or battery to the roof opening.

 When a Comfort Control Center 2 (herein-after referred to as CCC 2) thermostat is being installed with more than 2 zones, route a dedicated 12 Vdc supply wire (18-22 AWG) to zone 1 and zone 3 roof opening.

- a. This supply wire must be located in the front portion of the roof opening.
  - b. Make sure that at least 15" of supply wire extends into the roof opening.
3. Route a 4 conductor communication cable from the roof opening to the thermostat mounting location using the shortest most direct route. Make sure that at least 15" of the wire extends into the roof opening and 6" extends from the wall at the thermostat mounting location. See "E. Choosing Thermostat Locations" on page (8).

 When more than one unit is being installed (additional zones) with the CCC 2 thermostat, an additional 4 conductor communication cable **MUST** be routed to each additional unit roof opening. Make sure that at least 15" of the wire extends into the roof opening. See (FIG. 26).

4. Route an indoor temperature sensor (optional) from the roof opening to the indoor temperature sensor location. The 2 pin connector end goes to the roof opening. See indoor temperature sensor installation instructions for proper sensor location.

5. If system includes a gas furnace, route two 18 gauge thermostat wires from the furnace to the roof opening of the unit that will control it. If more than one furnace is to be used, route the second set of wires to the second unit. Make sure that at least 15" of the wire extends into the opening.
6. If an Energy Management System (load shed feature) is to be used with the control, two wires must be routed to the roof opening of the zone to be managed. The signal required for this function is normally an open relay contact. When the EMS calls for the compressor to shut off, the relay contacts should close. Make sure that at least 15" of the EMS wire extends into the roof opening.
7. If an Automatic Generator Start (AGS) kit will be installed, an additional 4 conductor communication cable must be routed from the last unit to the location of the AGS kit. Follow AGS kit instructions for installation.

## E. Choosing Thermostat Locations

1. If the system is to be used **WITHOUT** an optional indoor temperature sensor, the proper location of the CCC 2 thermostat is very important to ensure that it will provide a comfortable RV temperature. Observe the following rules when selecting a location:
  - Locate the thermostat 54" above the floor.
  - Install the thermostat on a partition, not on an outside wall.
  - **NEVER** expose the thermostat to direct heat from lamps, sun, or other heat producing items.
  - Avoid locations close to doors that lead outside, windows, or adjoining outside walls.
  - Avoid locations close to supply registers and the air from them.
2. If the system is be used **WITH** an optional indoor temperature sensor, the CCC 2 thermostat may be mounted anywhere in the RV that is convenient. Avoid hard to reach and hard to see areas.
  - a. Refer to the instructions provided with the indoor temperature sensor for details of installation.

## F. Thermostat, Optional Indoor Temperature Sensor & Thermostat Communication Cable Installation.

1. The previously run communication cable (4 conductor telephone cable) must be terminated with two (2) RJ-11-6C4P telephone connectors. Refer to the crimp tool manufacturer for crimping instructions. See (FIG. 7) & (FIG. 8).



# INSTALLATION INSTRUCTIONS

**i** RJ-11-6C4P connectors **MUST** be installed as shown in (FIG. 7) & (FIG. 8).

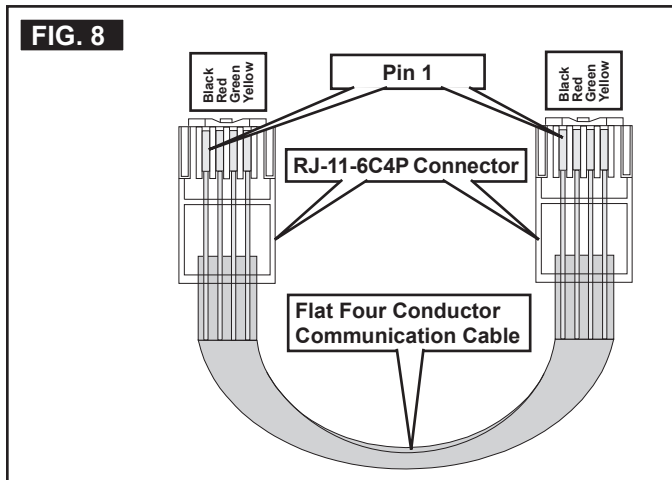
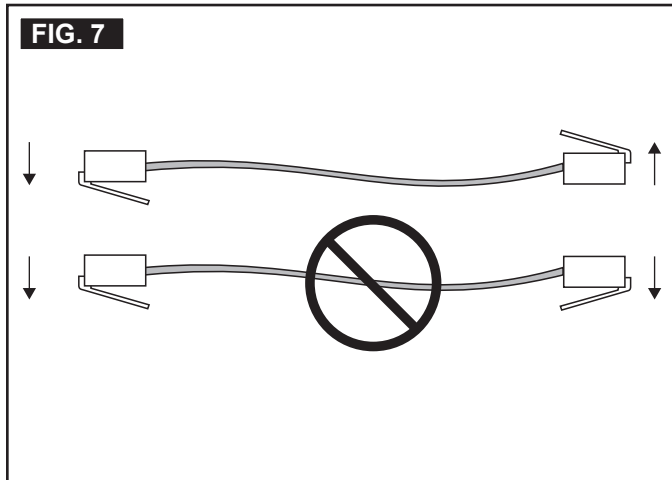

2. Route the communication cable through the 2" diameter hole in the wall required for the thermostat. See (FIG. 9).

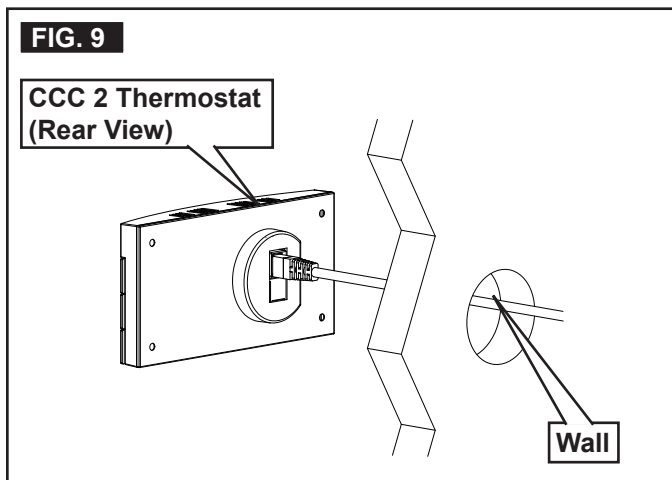

3. Optional Indoor Temperature Sensor
  - a. Refer to the instructions provided with the indoor temperature sensor for details of installation.
4. Thermostat Installation
  - a. Carefully separate the thermostat base plate from the thermostat cover. Insert a small screw driver into the slot on bottom of thermostat and disengage the tab. See (FIG. 10).

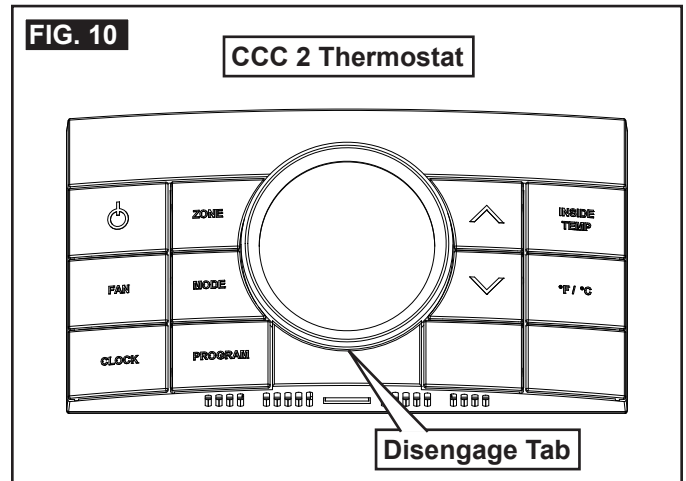

- b. Insert the 4 conductor communication cable through the hole in base plate. Align thermostat base plate with hole in wall. Make sure base plate is level and attach base plate to wall using the four (4) supplied screws.
- c. Insert the 4 conductor communication cable connector (RJ-116C4P) into the connector on the back of the thermostat. See (FIG. 11).

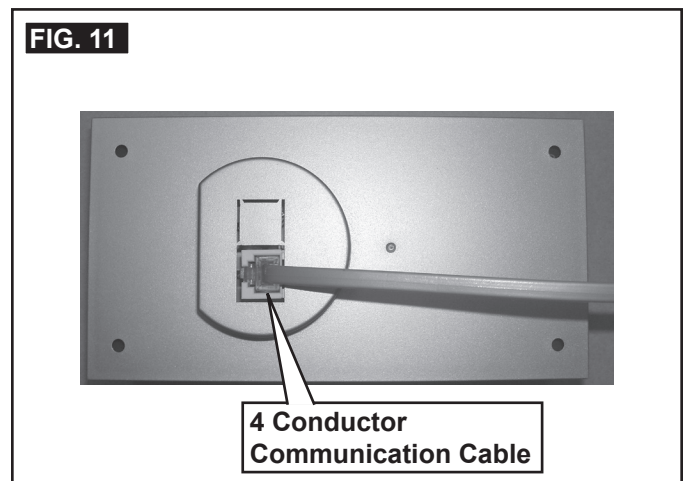

- d. Align the thermostat with the back plate and snap into position.

# INSTALLATION INSTRUCTIONS

## G. Placing Unit On Roof

1. Remove the unit from the carton and discard carton.
2. **CAUTION** LIFTING HAZARD. Use proper lifting technique and control when lifting product. Failure to obey this caution could result in injury. Place unit on roof.
3. **NOTICE** Do **NOT** slide unit. Otherwise, damage to gasket (on bottom of unit) may occur, and could cause a leak.  
Lift and place the unit over the prepared opening using the gasket on the unit as a guide. See (FIG. 12) & (FIG. 13).

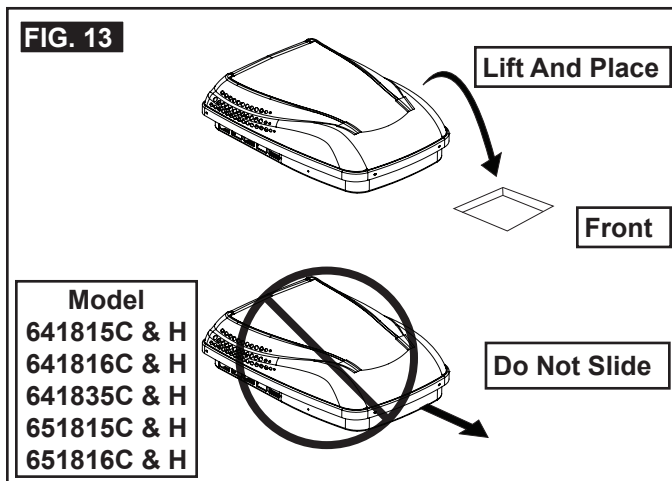
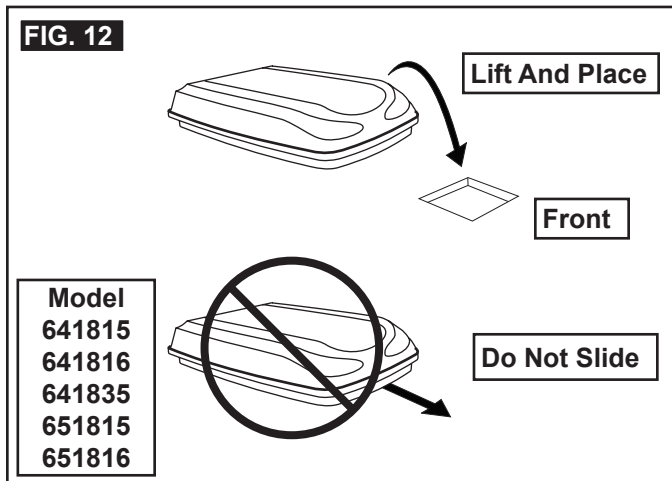

4. Place the electronic control box kit and the RAG kit inside the RV. These boxes contain mounting hardware for the unit and will be used inside the RV.

**i** This completes the outside work. Minor adjustments can be done from inside the RV if required.

## H. Installing Unit

1. Check gasket alignment of the unit over the roof opening and adjust if necessary. Unit may be moved from below by slightly lifting. See (FIG. 14).

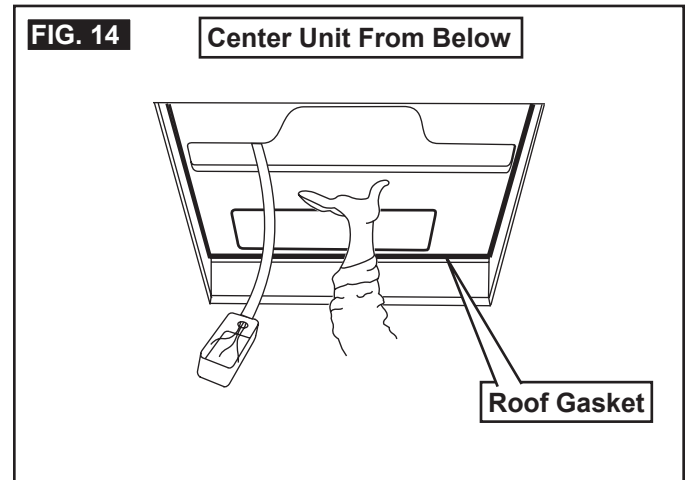

2. Remove return air cover and ceiling template from carton. See (FIG. 15).

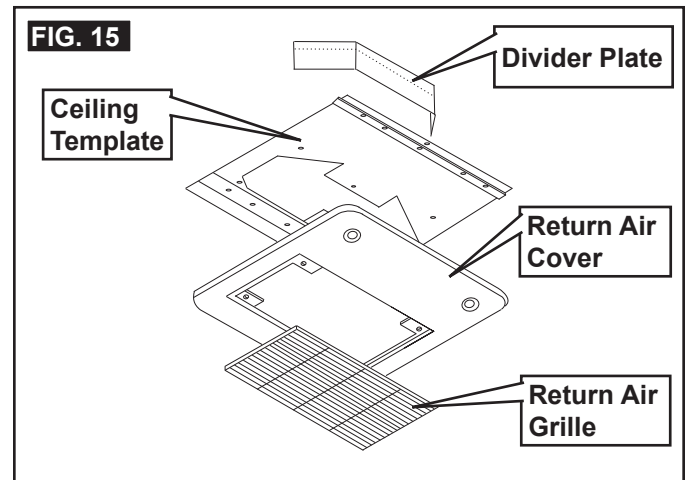

3. All models listed in this manual will use a four (4) bolt pattern for installing the RAG kit. These bolts along with the Romex connector and junction box cover are furnished in part number 3107180.006 (bolt kit) and is purchased separately.
4. Reach up into the return air opening and pull the unit electric cord down. Mount the junction box with screws to the framing in front of the roof opening. See (FIG. 16).

# INSTALLATION INSTRUCTIONS

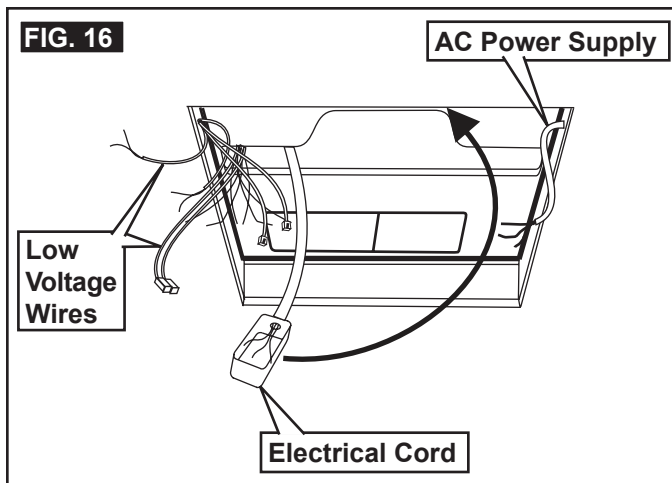

5. Install the Romex connector in the junction box.
6. Hold the ceiling template up to the roof opening. Make sure the large plate faces the rear of the RV. See (FIG. 17).
  - a. Start each mounting bolt through the ceiling template and up into the unit base pan by hand. Install wood screw in each end of the ceiling template. This ensures a tight fit of the return air cover to ceiling. See (FIG. 17)

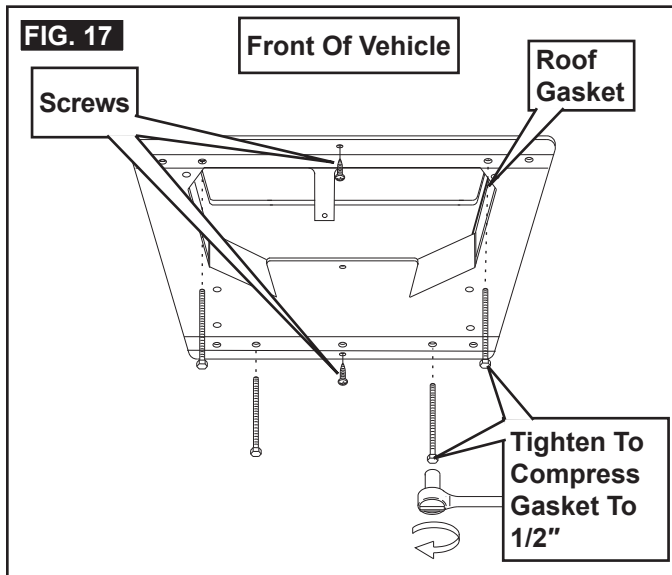

- b. **NOTICE** Tighten mounting bolts to correct torque specifications. Overtightening could damage unit's base pan or ceiling template. Not enough torque will allow an inadequate roof seal, and could cause a leak. Tighten all four (4) mounting bolts **EVENLY** within 40 to 50 inch pounds. See (FIG. 17).
  - i** This will compress the roof gasket to approximately 1/2".

## 7. Installation Of Divider Plate

- a. Measure the ceiling to roof thickness:
  - If distance is 2.0" - 3-3/4", remove perforated tab from divider plate. See (FIG. 18).
  - If distance is 3-3/4" - 5-1/2", remove no tabs.
- b. Remove the backing paper from double-sided tape located on ceiling template. See (FIG. 18).

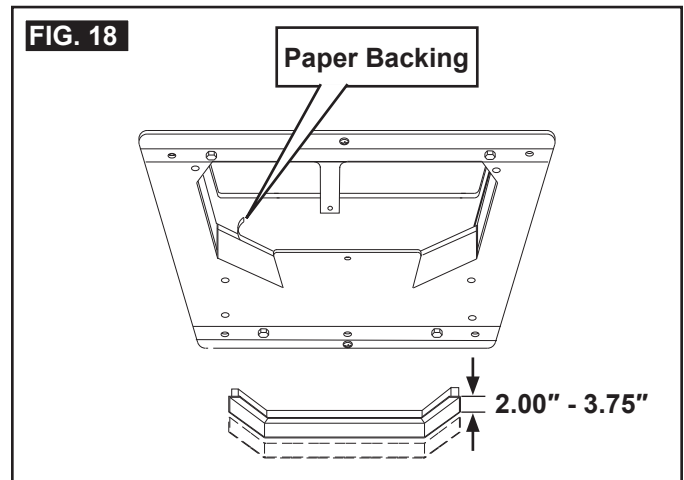

- c. **NOTICE** Divider plate **MUST** be installed correctly. Incorrect installation could cause compressor to quick-cycle, and could result in supply circuit overload and reduced product performance.

**i** The adhesive on the double-sided tape is extremely sticky. Make sure the divider plate is properly positioned before pressing into place.

Place the divider plate up to bottom of the unit base pan firmly. The foam tape on the divider plate must seal to bottom of base pan. See(FIG. 19).

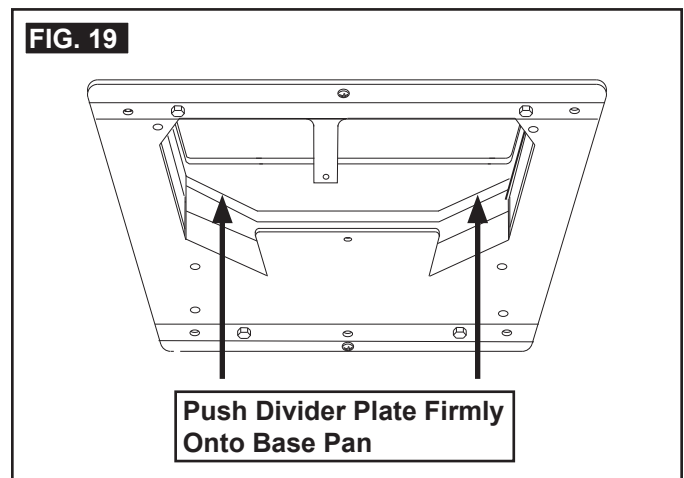

# INSTALLATION INSTRUCTIONS

- d. With slight pressure push the divider plate against the double-sided tape on the ceiling template.
- e. Locate the 1/8" x 7" x 18" self-adhesive insulation supplied with the RAG kit. Remove the backing paper from the insulation and carefully stick onto the ceiling template divider plate. See (FIG. 20).

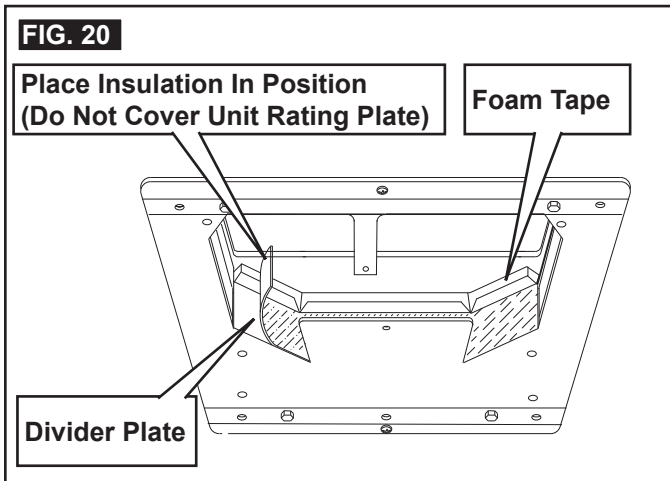

- Excess width is intended to seal the divider plate to the sides of the roof opening. This is to help prevent cold air discharge from circulating into the unit return air opening.
- If the insulation is too high, stick excess height of the insulation to the unit base pan. Do not cover up unit rating plate.

## I. Wiring System

Reach up into the return air opening and pull down the remaining wires. See (FIG. 15).

### 1. Low Voltage Wire Connections

- a. **NOTICE** Make sure the positive (+) 12 Vdc terminal is disconnected from supply battery. Otherwise, damage to unit could occur.
- b. Connect the previously run 12 Vdc wires to the red and black wires protruding from the unit return air opening. Connect +12 Vdc to the red wire; -12 Vdc to the black wire.
- c. Connect the previously run furnace wires (if applicable) to the blue wires protruding from the return air opening. The polarity of these connections does not matter.
- d. Terminate the 4 conductor communication cable(s) protruding from the roof opening. The cable(s) must be terminated with a telephone RJ-11-6C4P connector. Refer to the crimp tool manufacturer for crimping instructions.

**i** RJ-11-6C4P connectors **MUST** be installed as shown in (FIG. 7) & (FIG. 8).

- e. Plug the 4 conductor communication cable into one of the RJ-11-6C4P telephone couplers protruding from the return air opening. If more than one zone is used, the second coupler is used to join each additional zone.
  - f. Plug the indoor temperature sensor cable (if applicable) into the P4 (white) 2 pin matching connector protruding from the return air opening.
  - g. Connect the previously run Energy Management System wires (if applicable) to the yellow wires protruding from the return air opening. The polarity of these connections does not matter.
  - h. If an Automatic Generator Start (AGS) kit is installed, follow installation instructions furnished with AGS kit.
2. 120 Vac Power Supply Connection
    - a. **WARNING** ELECTRICAL SHOCK HAZARD. Make sure 120 Vac power is disconnected from RV. Failure to obey this warning could result in death or serious injury.
    - b. **WARNING** ELECTRICAL SHOCK HAZARD. Provide grounding in compliance with all applicable electrical codes. Failure to obey this warning could result in death or serious injury.
    - c. Route the previously run 120 Vac power supply wire through the strain relief and into the junction box. Tighten strain relief making sure not to damage wires. Leave enough wire inside junction box to connect to unit 120 Vac wires.
    - d. Connect white to white; black to black; and green to green or bare copper wire using appropriate size connectors.
    - e. Tape the connectors to the supply wire to ensure they don't vibrate loose.
    - f. Push wires into the box and install cover.

## J. System Configuration

Now that the system is installed, it is necessary to do a system configuration.

### 1. Electronic Control Configuration

Depending on the equipment options installed by the RV manufacturer, the appropriate dip switches will need to be switched to the "ON" position. Placing the switch in the "ON" position selects that option. See (FIG. 21) & (FIG. 22) & (FIG. 23).

# INSTALLATION INSTRUCTIONS

FIG. 21

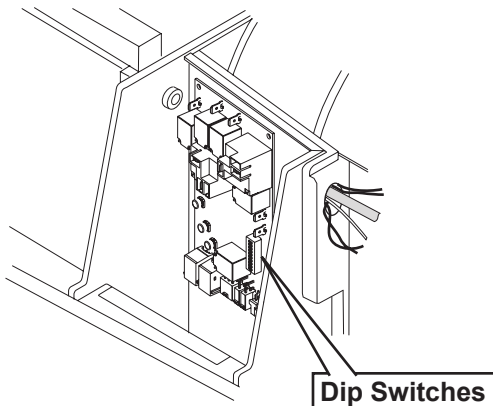

**i** Dip switches are in the “OFF” position when shipped from the factory except heat pump models. On these models the appropriate dip switch is in the “ON” position from the factory. They are visible through the opening in the electronic control box.

To gain access to the dip switches on models with board built in, the outside plastic shroud **MUST** be removed from the unit. Next remove the electrical box cover. The electrical box will be on the curb side of the RV after installation. See (FIG. 22).

FIG. 22

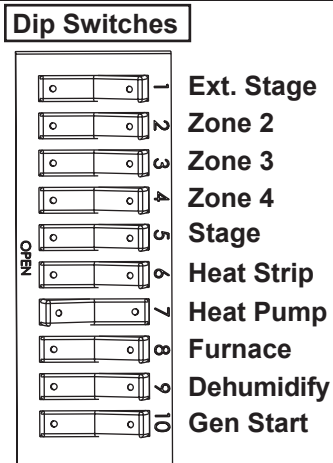

- Ext. Stage - Ext. Stage is not used on this unit. Leave in the “OFF” position.
- Zone selection - Each CCC 2 thermostat can have up to 4 zones. When only one unit is installed it becomes Zone 1 and no dip switch setting is required. Each additional unit must be assigned a zone (2 through 4). Each unit must have a different zone setting.
- Stage selection - Stage is not used on this unit. Leave in the “OFF” position.

- Heat Strip - On heat strip models the #6 dip switch is in the “ON” position from the factory. Non heat strip models leave in the “OFF” position.
- Heat Pump - On heat pump models the #7 dip switch is in the “ON” position from the factory. Non heat pump models leave in the “OFF” position.
- Furnace - If a Furnace/Aqua heat system has been connected to this unit, the furnace dip switch must be placed in the “ON” position.
- Dehumidify - Dehumidify is not used on this unit. Leave in the “OFF” position.
- Gen Start selection - Leave in the “OFF” position.
- Install electronic control box cover.
- Repeat this procedure for each additional zone.

FIG. 23

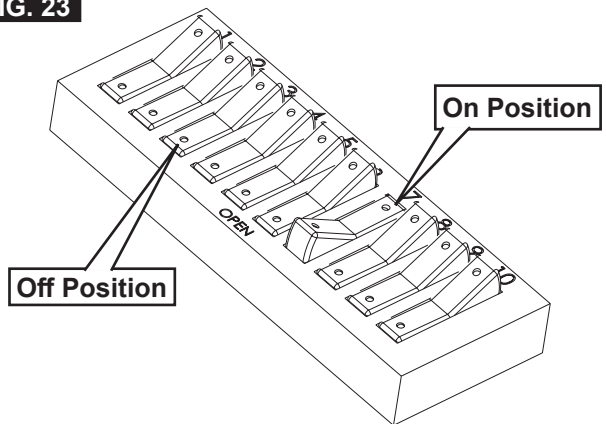

## K. Installing Return Air Cover

- i** Remove the return air grille from the return air cover.
- Place the return air cover up to the ceiling template.
- Install cover to template using six (6) supplied #8 x 3/8” blunt point Phillips head screws.
- Re-install filter return air grille into return air cover. Align tabs with mating notches and snap into place.
- Install two (2) hole plugs into screw holes in back of return air cover. See (FIG. 24).

# INSTALLATION INSTRUCTIONS

FIG. 24

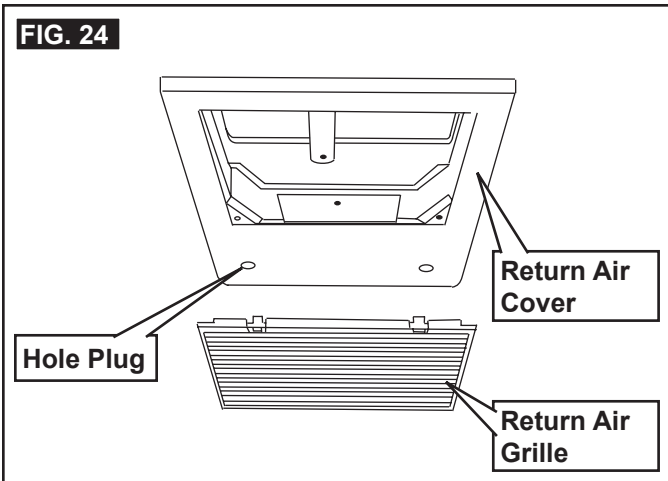

## L. System Reset & Checkout

### 1. System Reset

After setting the dip switches in the electronic control, do a system reset.

- Re-connect the 12 Vdc and 120 Vac power supplies.
- Make sure the CCC 2 thermostat is in the **OFF** mode.
- Simultaneously press the **MODE** and **Zone** buttons. The LCD will display "Init" and all available zones.
- Release the **MODE** and **Zone** buttons.
- Press the **ON/OFF** button to exit system set up.
- When a dip switch is turned on after initial configuration, a system reset will need to be done before the CCC 2 thermostat will recognize the updated selection.

### 2. System Checkout

- Verify that all features of the installed system work. See CCC 2 thermostat Operating Instructions or User's Guide. Check the fan mode, cooling mode, heat pump mode (if applicable), and furnace mode (if applicable) operation. If the features do not work disconnect the 120 Vac and 12 Vdc power supplies and verify that all wiring is correct and that the correct dip switches have been set to the "ON" position.

## M. Furnace /Aqua Temperature Differential Setting

This system can be configured to operate using an ON/OFF differential of either 1 degree F or 2 degree F. See (FIG. 25).

- To set the differential, simultaneously press the **PROGRAM** button and the  $\wedge$  up button on the CCC 2 thermostat. "diF1" will appear in the display while the buttons are pressed. See (FIG. 25). To set the 2 degree differential, simultaneously press the **PROGRAM** button and the  $\vee$  down button. "diF2" will appear in the display while the buttons are pressed.

FIG. 25

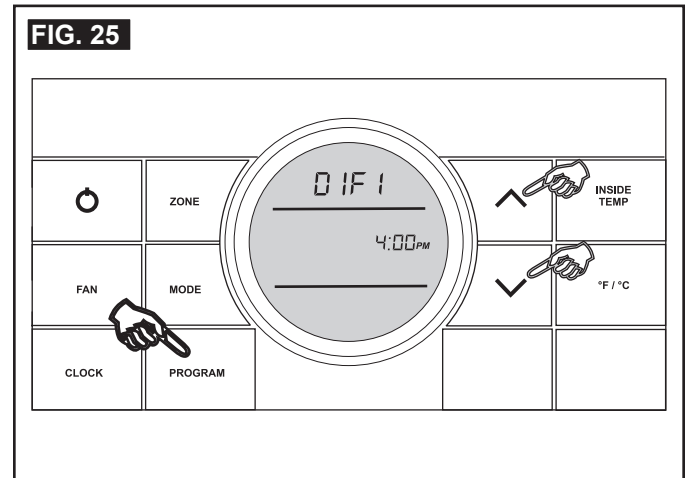



# GENERAL INFORMATION

## A. Frost Formation On Cooling Coil

Frost on a small portion of the coil is not unusual. Under certain conditions, ice may form on the evaporator coil. This is indicated by very cold output at very low air speed and the icing can be seen through the air inlet hole with the filter removed. If this should occur, inspect the filter and clean if dirty. Make sure air vents are open and not obstructed. Units have a greater tendency to frost when the outside temperature is relatively low. This may be prevented by adjusting the thermostat control knob to a warmer setting (counter clockwise). Should frosting continue, operate on any FAN ONLY setting until the cooling coil is free of frost; then resume normal operation. If frost condition persist, contact your local service center for assistance.

## B. Condensation

The manufacturer of this unit will not be responsible for damage caused by condensation forming on ceilings, windows, or other surfaces. Air contains water vapor which condenses when temperature of a surface is below Dew point. During normal operation this unit is designed to remove a certain amount of moisture from the air, depending on the size of the space being conditioned. Keeping doors and windows closed when this air conditioner is in operation will greatly reduce the chance of condensation forming on interior surfaces.

## C. Air Distribution

Each A/C unit operating in cool mode, must have a minimum of 2 distribution vents, or the quick cool vent and one vent open, to avoid the risk of freezing coils and improper function.

# WIRING DIAGRAMS

## A. Simple RV Wiring Diagram

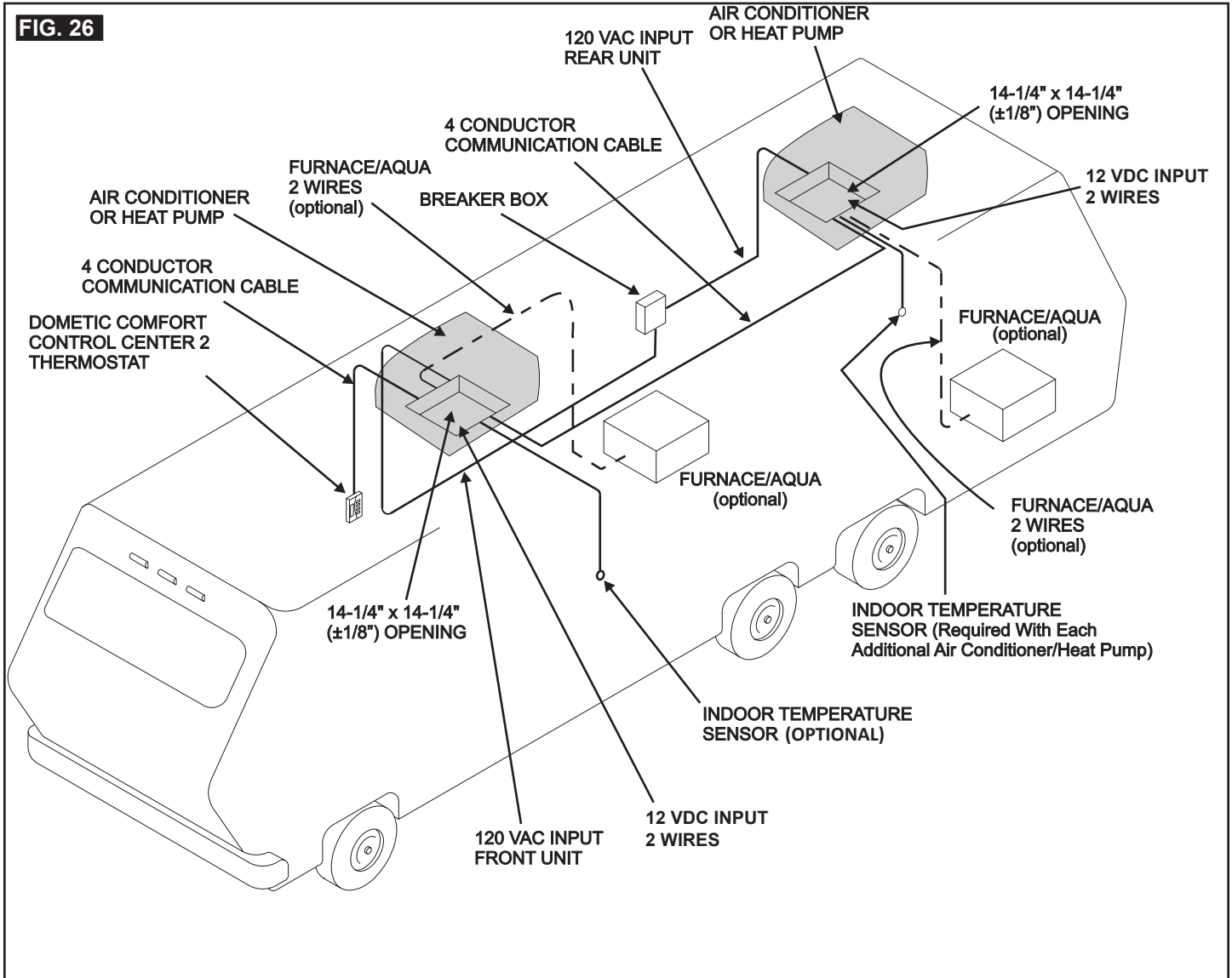

# WIRING DIAGRAMS

## B. Unit Wiring Diagrams

### 1. 641815, 641816 & 641835 Wiring Diagram

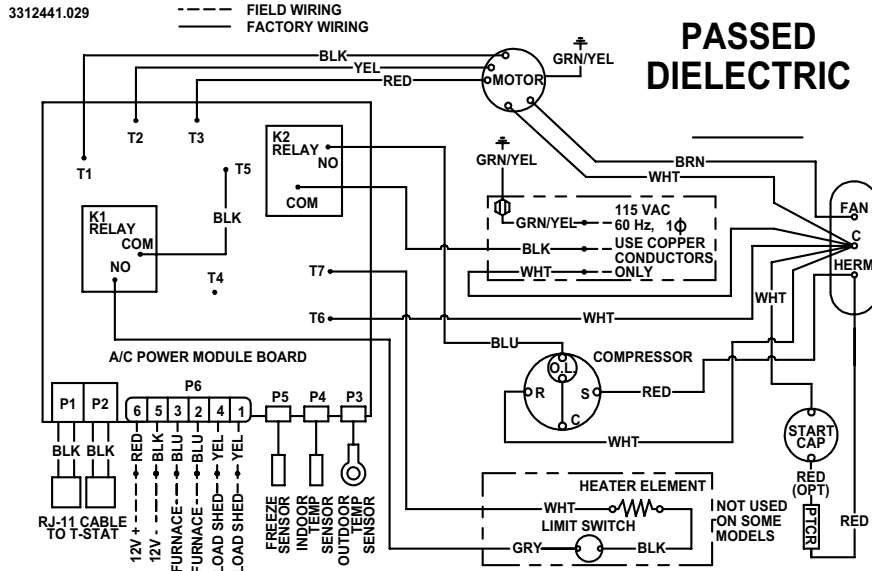

### 2. 651815 & 651816 Wiring Diagram

