



DF Series Furnace

Models DFSAD12, DFSD12, DFSD16, DFSD20, DFMD16, DFMD20, DFMD25, DFMD30, DFMD35, DFLD35, DFLD40, DFLA35, DFLA40

INTRODUCTION	2
IMPORTANT SAFETY INSTRUCTIONS AND DOCUMENT SYMBOLS.....	2
OPERATION	4
INSPECTION AND MONTHLY MAINTENANCE	5
ANNUAL MAINTENANCE.....	7
TROUBLESHOOTING	7
REPLACEMENT PARTS.....	7
WARRANTY	8

⚠ WARNING:

FIRE OR EXPLOSION HAZARD

Failure to follow safety warnings exactly could result in serious injury, death or property damage.

- Do not store or use gasoline or other flammable vapors and liquids in the vicinity of this or any other appliance.
- **WHAT TO DO IF YOU SMELL GAS**
 - Evacuate all persons from the vehicle.
 - Shut off the gas supply at the gas container or source.
 - Do not touch any electrical switch, or use any phone or radio in the vehicle.
 - Do not start the vehicle's engine or electric generator.
 - Contact the nearest gas supplier or qualified service technician for repairs.
 - If you cannot reach a gas supplier or qualified service technician, contact the nearest fire department.
 - Do not turn on the gas supply until the gas leak(s) has been repaired.
- Installation and service must be performed by a qualified installer, service agency, or the gas supplier.



Read these instructions carefully. These instructions MUST stay with this product.

INTRODUCTION

This manual is intended for reference on the safe operation and maintenance of the Dometic DF Series Furnace. Should you require further information, contact Dometic. This DF Series Furnace (hereinafter referred to as "Furnace") has been certified and designed as an MSP Category III Furnace and is intended for use inside a recreational vehicle (hereinafter referred to as "RV"). Follow these instructions to ensure the correct operation and maintenance of the Furnace. Failure to operate and maintain the Furnace according to these operating instructions nullifies the Furnace warranty.

Dometic Corporation reserves the right to modify appearances and specifications without notice.

IMPORTANT SAFETY INSTRUCTIONS AND DOCUMENT SYMBOLS

This manual has safety information and instructions to help you eliminate or reduce the risk of accidents and injuries.

A. Recognize Safety Information



This is the safety alert symbol. It is used to alert you to potential physical injury hazards. Obey all safety messages that follow this symbol to avoid possible injury or death.

B. Understand Signal Words

A signal word will identify safety messages and property damage messages, and will indicate the degree or level of hazard seriousness.

indicates a hazardous situation that, if **NOT** avoided, could result in death or serious injury.

indicates a hazardous situation that, if **NOT** avoided, could result in minor or moderate injury.

is used to address practices **NOT** related to physical injury.



Indicates additional information that is not related to physical injury.

C. Supplemental Directives



Read and follow all safety information and instructions to avoid possible injury or death.

Read and understand these instructions before installation of this product.

Incorrect installation of this product can lead to serious injury or death.

The installation **MUST** comply with all applicable local or national codes, including the latest edition of the following standards:

U.S.A.

- ANSI/NFPA70, National Electrical Code (NEC)
- ANSI/RVIA LV, Low Voltage Systems in Conversion and Recreational Vehicles
- ANSI/NFPA 1192, Recreational Vehicles Code
- ANSI Z223.1, NFPA 54 National Fuel Gas Code
- ANSI 1195, Park Trailers

CANADA

- CSA C22.1, Parts I & II, Canadian Electrical Code
- CSA Z240 RV Series, Recreational Vehicles
- CAN/CGA B149, Natural Gas and Propane Installation Code

D. General Safety Messages

Failure to obey the following warnings could result in property damage, serious injury, or death:

- This Furnace **MUST** be installed, repaired, and serviced by a qualified service technician.
- Do **NOT** modify this Furnace in any way. Modification can be extremely hazardous.

IMPORTANT SAFETY INSTRUCTIONS AND DOCUMENT SYMBOLS

- FIRE OR EXPLOSION HAZARD:
 - Do **NOT** store gasoline, oil- or gasoline-soaked rags, or other flammable vapors and liquids inside storage compartment(s).
 - **BEFORE** refueling or parking near a gasoline pump, make sure ALL liquid propane (LP) gas appliances (vented to the outside of the RV) are shut OFF. Otherwise, fumes from gasoline pumps could come into contact with an LP gas appliance burner flame and ignite.
 - Turn OFF LP gas supply at the tank.
 - Keep the Furnace area free and clear of insulating material, as insulating materials may be combustible. Examine the Furnace area after installation or when insulation is added.
 - Use only with the type of gas approved for the Furnace. Refer to the Furnace rating plate.
 - All DFSA, DFS, DFM, and DFLD models: LP ONLY
 - All DFLA models: LP or Natural Gas
 - Do **NOT** overfill LP gas tanks. LP tanks must be filled by a qualified gas supplier only. Follow the tank manufacturer's operating instructions located on the tank.
 - Immediately shut down the Furnace and call a service agency if the Furnace cycles erratically or delays on ignition.
 - Shut OFF the gas valve to the Furnace before shutting off the electrical supply if the gas supply fails to shut off, or if overheating occurs.
 - Use only Dometic replacement parts and components, which are specifically approved for use with the Furnace.
- CRITICAL OPERATION WARNINGS:
 - Do **NOT** use the Furnace cabinet area as a storage compartment.
 - Do **NOT** keep insulating material, clothing, or flammable material on or near the Furnace.
 - Do **NOT** use for temporary heating of buildings or structures under construction.
 - Do **NOT** use the Furnace if any part has been under water.
 - Do **NOT** use petroleum or citrus-type cleaner on plastic parts, as damage may occur.
 - Do **NOT** restrict the ducting or block Furnace outlet registers and return-air grills.
 - Do **NOT** install screens over the intake air or exhaust vents for any reason.
 - Do **NOT** install air boosters in the duct system.
 - Do **NOT** touch exterior exhaust grills when the Furnace is operating.
 - Supervise young children who are in the same room as the Furnace.
 - All sheet metal edges are sharp; take care when handling or touching edges.
 - Protect Furnace electrical components from water.
 - Protect building materials from degrading from vent assembly gas exhaust.
 - Compartment must be closed when operating the Furnace.
- CARBON MONOXIDE HAZARD:
 - This Furnace can produce carbon monoxide, which has no odor and can be life-threatening. The burner and vent assembly system **MUST** be kept clean.
 - Do **NOT** operate the Furnace if venting into a room enclosure with the privacy panels closed. At least one panel **MUST** be open for ventilation when using the Furnace.
 - Doors **MUST** be properly sealed and the draft cap and assemblies **MUST** be adjusted and sealed correctly to prevent carbon monoxide from entering the RV.
 - Do **NOT** allow snow or any objects to block the exhaust system of the Furnace.
 - Combustion products **MUST** be properly vented to the atmosphere, so that all combustion air supplied to the burner is drawn from the outside atmosphere.
 - Use only Dometic replacement parts and components, which are specifically approved for use with the Furnace.
- ELECTRICAL SHOCK HAZARD:
 - Furnaces with 12 VDC connection are for low-voltage battery or direct current only. Do **NOT** connect to 120 or 240 VAC.
 - This Furnace is designed for negative ground 12 VDC only. Do **NOT** attempt to alter the Furnace for a positive ground system or connect the Furnace directly to 120 or 240 VAC.
 - Do **NOT** use battery charger to supply power to DC model Furnaces even when testing.
 - Use only Dometic replacement parts and components, which are specifically approved for use with the Furnace.

OPERATION

⚠ WARNING FIRE OR EXPLOSION HAZARD. Failure to obey the following warnings could result in property damage, serious injury, or death:

- This Furnace does not have a pilot. It is equipped with an ignition device that automatically lights the burner. Do **NOT** try to light the burner by hand.
- **BEFORE OPERATING THE FURNACE**, check around the Furnace area and floor for the smell of gas and check the fitting with a leak test solution. Do **NOT** proceed if a gas odor exists around the Furnace or floor area. Follow the instructions in the warning box on the cover page.
- Turn the gas control valve by hand **ONLY**. **NEVER** use tools. If the valve does not turn by hand, do **NOT** attempt to repair it. Call a qualified service technician.

i Read the following **BEFORE** proceeding:

- During the initial firing of the Furnace, a burn-off of excess paint and oils remaining from the manufacturing process may cause "smoking" for 5 – 10 minutes.
- The Furnace is equipped with a power switch. Gas will not flow to the burner and the Furnace will not operate with the switch in the OFF position.
 - Door models have a power switch located inside of the door.
 - Non-door models (LD or Small Vent) have a power switch on the outside of the Furnace.

A. Turning On The Furnace

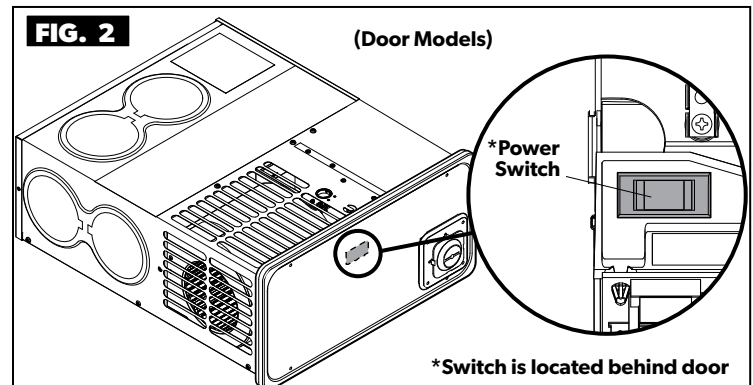
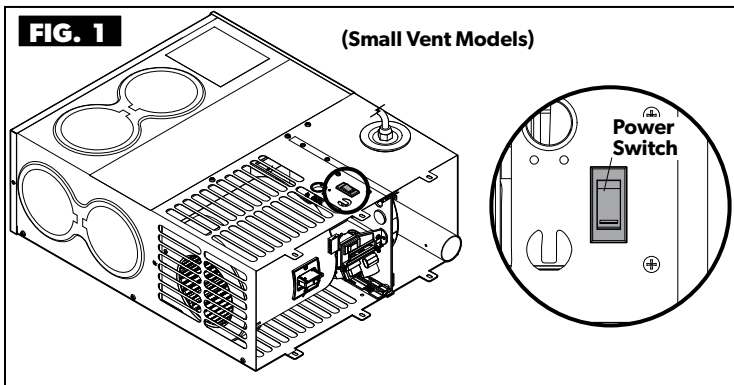

- Turn the thermostat to the lowest setting.
- Turn OFF all power to the Furnace at the main power supply.
- At the exterior access panel, turn the switch on the Furnace to the OFF position.
- Wait five minutes, then check for a gas odor.
 - If a gas odor exists around the Furnace or floor area, follow the instructions in the warning box on the cover page.
 - If no gas odor is present, proceed to the next step.
- At the exterior access panel, turn the switch on the Furnace to the ON position.
- Turn ON the main power supply.
- Set the thermostat to the desired temperature.

i If the Furnace will not operate, follow the instructions for "B. Turning Off The Furnace" on page 5 and call a qualified service technician.

OPERATION

B. Turning Off The Furnace

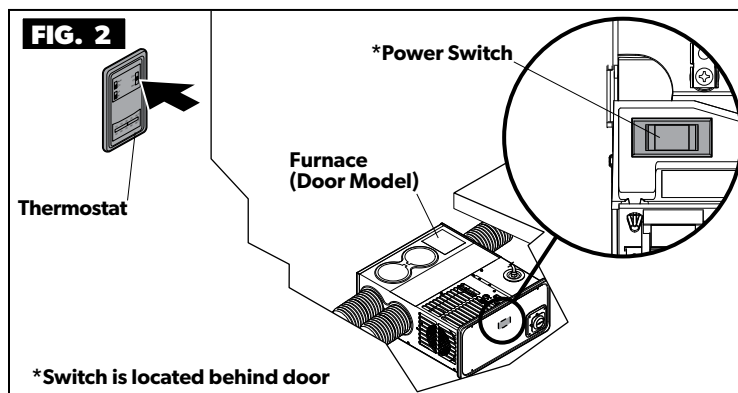
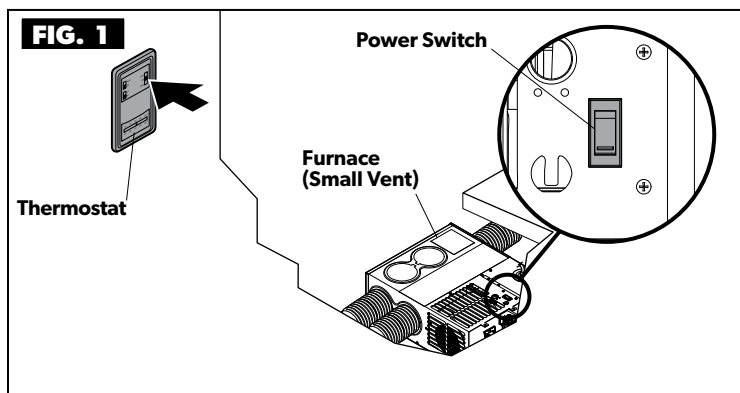

- Set the thermostat to the lowest setting, then turn to the OFF position.
- Turn the manual shut-off valve at the LP tank (if equipped) to the OFF position. Do **NOT** force the valve.
- At the exterior access panel, turn the switch on the Furnace to the OFF position.

INSPECTION AND MONTHLY MAINTENANCE

⚠ WARNING ELECTRICAL SHOCK, FIRE, OR EXPLOSION HAZARD. Failure to obey the following warnings could result in dangerous operation, property damage, serious injury, or death:

- Never attempt to repair the Furnace yourself. Contact a qualified service technician.
- Improper servicing could result in dangerous operation, serious injury, death, or property damage.
 - Before servicing, disconnect all electrical power to the Furnace.
 - When servicing the controls, label all the wires prior to disconnecting. Reconnect the wires correctly.
 - Verify proper operation after servicing.
- Keep the Furnace, control compartments, burners, and circulating air passageways clean and unobstructed. More frequent cleaning may be required from excessive lint from carpeting, bedding materials, pet hair, etc.
- Do **NOT** use petroleum or a citrus-type cleaner on plastic parts, as damage may occur.

NOTICE The motor is permanently lubricated and requires no oiling.

A. Servicing And Maintenance

i Annual inspections should be performed by a qualified service technician.

MONTHLY	ANNUALLY
To be performed by owner/user:	To be performed by qualified service technician:
VENTS AND EXHAUST TUBES: Refer to "B. Inspecting The Vents And Exhaust Tubes" on page 6.	Refer to "Annual Maintenance" on page 7.
CHAMBER: Refer to "C. Inspecting The Chamber" on page 6.	
MOUNTING BASE: Refer to "D. Inspecting The Base" on page 6.	
VENT ASSEMBLY: Refer to "E. Inspecting The Vent Assembly" on page 6.	

INSPECTION AND MONTHLY MAINTENANCE

B. Inspecting The Vents And Exhaust Tubes

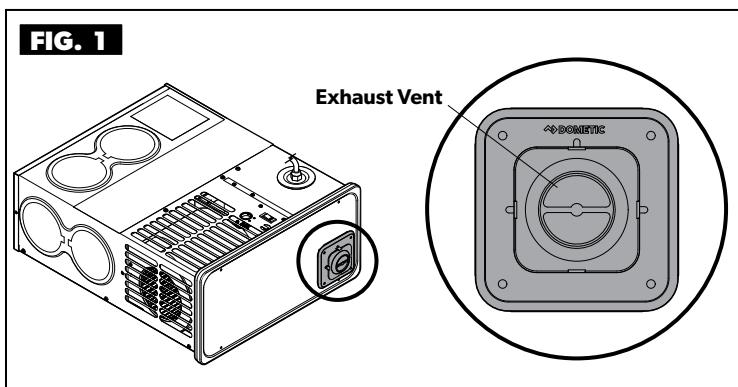

- Inspect the Furnace venting. Confirm the vents properly expel exhaust into the atmosphere and that the vent assembly is positioned tightly against the outer door.
- Inspect the vent for obstructions or the presence of soot. If soot is present, immediately shut the Furnace OFF and contact your dealer or a qualified service technician.

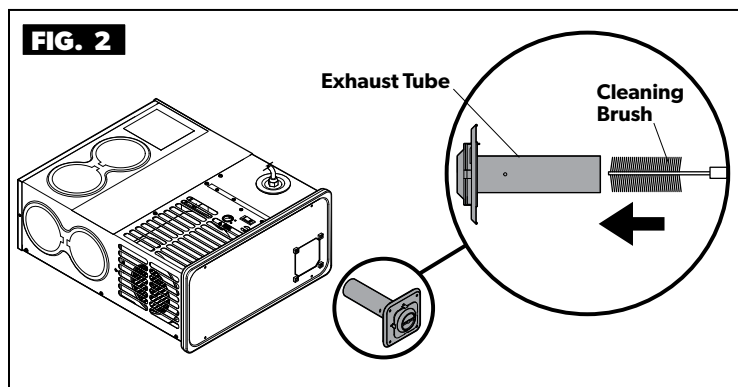

- Inspect the Furnace exhaust tubes for blockage, overlap, holes, or soot.
- All exhaust system tubes **MUST** overlap no less than 1-1/4".
- All air intake tubes **MUST** overlap no less than 1/2".
- Keep tubes clean and free of obstructions.

C. Inspecting The Chamber

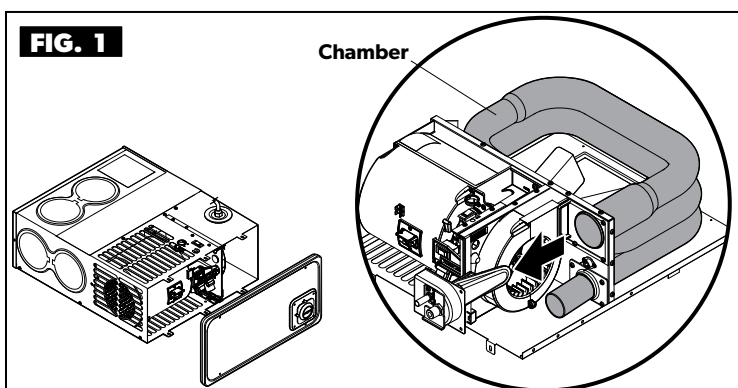

- Inspect the chamber and vent system for holes or excessive corrosion.

D. Inspecting The Base

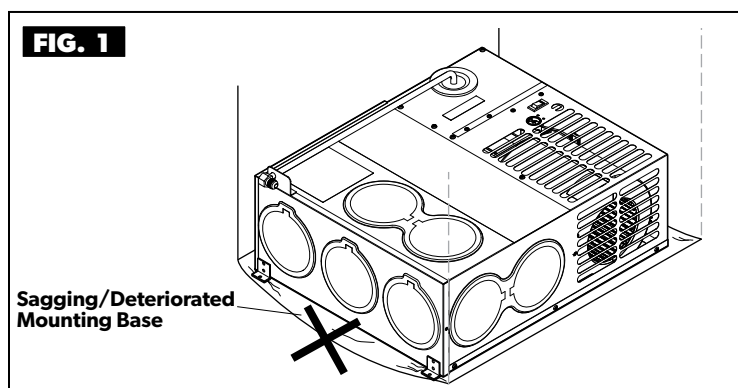

- Confirm the Furnace mounting base is not sagging or deteriorating.

E. Inspecting The Vent Assembly

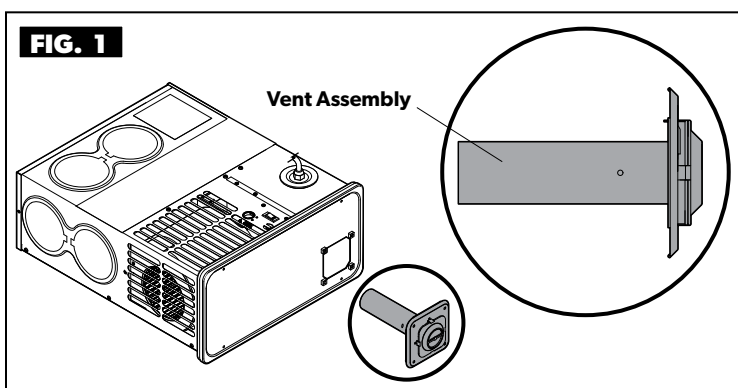

- Inspect the Furnace, venting, ducting, and gas piping for obvious signs of deterioration. Correct any defects.

ANNUAL MAINTENANCE

⚠ WARNING ELECTRICAL SHOCK, FIRE, OR EXPLOSION HAZARD. Failure to obey the following warnings could result in dangerous operation, property damage, serious injury, or death:

- Improper servicing could result in dangerous operation, serious injury, death, or property damage.
 - Before servicing, disconnect all electrical power to the Furnace.
 - When servicing the controls, label all the wires prior to disconnecting. Reconnect the wires correctly.
 - Verify proper operation after servicing.
- Failure to properly maintain the Furnace may void the Furnace warranty and can result in property damage, serious injury, or death.

i A qualified RV service technician should perform the following preventative maintenance and safety checks ANNUALLY.

AIR WHEEL: Clean and clear any obstructions.	GASKETS: Inspect all gaskets for tight seals.
ORIFICE INSPECTION: Inspect the orifice annually.	GENERAL: Check physical support system for sagging cracks, gaps, etc.
BURNER: Requires no adjustment, inspect annually. Clean burner with a wire brush to remove debris and corrosion build up.	MOTOR: Requires no oiling. Permanently sealed and lubricated. Inspect annually.
CONTROL COMPARTMENT: Remove dirt and lint.	RETURN AIR: Clean and clear obstructions.
DUCTING: Clean and clear obstructions. Reconnect any ducts that have become loose.	VENTING: Check position of exhaust tube and Furnace chamber tube.
GAS PRESSURE TEST: Test the entire piping system. Test the gas connections for leaks with a leak test solution.	VOLTAGE: Check power with applicable power sources (generator, battery, and converter).
GAS SUPPLY SYSTEM: Perform a pressure drop test according to current ANSI standards.	WIRE CONNECTIONS: Check for loose, disconnected, or worn insulation areas.

TROUBLESHOOTING

ISSUE	SOLUTION
Furnace will not light – Blower does not turn on.	<ol style="list-style-type: none"> 1. Check the main fuse panel for a blown fuse. 2. The Furnace-installed breaker switch may be tripped or OFF – Contact a trained RV service provider. 3. The 12 VDC power is low; check the RV system voltage. 4. The Furnace may be in lockout. Reset the Furnace by switching the thermostat to OFF for 10 seconds, then switch the thermostat to ON. If air is in the propane line, repeat this process up to three times. 5. Check the intake and vents to make sure they are not blocked or obstructed.
Furnace will not light – Blower does turn on.	<ol style="list-style-type: none"> 1. Air is in the LP line. Purge the air by turning on other appliances (like a cooktop) that are further downstream from the LP tanks. 2. The thermostat is not set to Heat or a high enough temperature. Adjust the thermostat.
Furnace shuts off before it reaches the desired temperature.	<ol style="list-style-type: none"> 1. Check to make sure all the vents are open and not covered. 2. Check the air intake to make sure it is not blocked or obstructed.

REPLACEMENT PARTS

⚠ WARNING ELECTRICAL SHOCK, FIRE, EXPLOSION AND/OR CARBON MONOXIDE HAZARD. Use only Dometic replacement parts and components, which are specifically approved for use with the Furnace. Failure to obey this warning could result in dangerous operation, property damage, serious injury, or death:

- For replacement part information, see the DF Series Furnace Parts List. For the most current information, visit www.eDometic.com.



LIMITED TWO-YEAR WARRANTY (FURNACES)

THE SELLER NAMED BELOW MAKES THE FOLLOWING WARRANTY WITH RESPECT TO THE DOMETIC PRODUCT:

1. This Warranty is made only to the first purchaser (hereinafter referred to as the "Original Purchaser"), who acquires the Dometic Product for his or her own use and when the Dometic Product is installed and operated within the continental United States and Canada.
2. **WARRANTY PERIOD:** This Warranty will be in effect for two (2) years from the date of purchase by the Original Purchaser. The Original Purchaser should retain a copy of the dated bill of sale as evidence of the date of purchase.
3. **WARRANTY:** This Warranty covers labor, specified parts, and freight. The Dometic Product shall be free from defects in material and workmanship at the time of sale and under normal use. All Dometic Products (except those specifically built for commercial use) are warranted only when installed per the Seller's installation instructions on vehicles built to R.V.I.A. A119-2 and C.R.V.A. Z-240 Standards. This Warranty does NOT cover conditions unrelated to the material and workmanship of the Dometic Product. Such unrelated conditions include, but are not limited to: (a) damage not reported within 10 days of ownership; (b) failure or damage caused by storms, rain, water pooling, or any acts of God; (c) faulty installation or installation that does not comply with the Seller's instructions or R.V.I.A. and C.R.V.A. standards, and any damage resulting from such; (d) damage or failure caused by installation of accessories not manufactured and marketed by the Seller or any non-Dometic parts that are installed as replacement parts; (e) the need for normal maintenance and any damage resulting from the failure to provide such maintenance; (f) failure to follow Seller's instructions for use of this Dometic Product; (g) any accident to, or misuse of, any part of the Dometic Product and any alteration by anyone other than the Seller or its authorized representative; (h) cosmetic issues caused during installation; (i) normal wear; (j) Dometic Product abuse; (k) corrosion caused by salt water; (l) any item that restricts airflow including but not limited to bug screens and (m) defects caused by improper ducting
4. **WARRANTY COVERS DOMETIC COMPONENT PARTS:** All Dometic component parts are covered under this Limited Warranty.
5. It is suggested that the Original Purchaser provide regular preventative maintenance, most of which on a yearly basis. The preventative maintenance suggested is: (a) inspect/clean the burner; (b) removal of bug nests; (c) inspect blower wheel. The cost of this preventative maintenance is the Original Purchaser's responsibility and the preventative maintenance should take about one hour.
6. **WARRANTY REMEDY:** In order to obtain the benefits of this Warranty, the Original Purchaser has the following two options during the WARRANTY PERIOD:
 - a. Preferred option: Deliver the Dometic Product for inspection to the nearest Authorized Dometic Service Center during the Warranty Period. To obtain the location of the nearest Authorized Dometic Service Center, refer to <https://www.dometic.com/en-us/us/find-a-dealer>. The Authorized Dometic Service Center will work with the Seller to obtain Warranty coverage if a Seller defect is identified. **CONFIRM THE SERVICE CENTER IS AN AUTHORIZED DOMETIC SERVICE CENTER. DO NOT PAY THE SERVICE CENTER FOR WARRANTY REPAIRS.**
 - b. Second option: If it is not feasible under the circumstances to deliver the Dometic Product to an Authorized Dometic Service Center, please call 1-800-544-4881 for additional Warranty assistance. Seller prefers option a. first and only option b. if option a. is determined not to be feasible under the circumstances.
7. Any item returned in the manner described in paragraph 6 will be examined by the Authorized Dometic Service Center. If it is found that the returned item was defective in material and workmanship at the time of sale, the Authorized Dometic Service Center will contact the Seller for Warranty coverage. The Seller shall, at Dometic's sole option, repair or replace the Dometic Product, or refund Original Purchaser's purchase price. If the Seller determines that repairs to the Dometic Product are to be made, then only authorized Dometic parts will be used.
8. The Seller does not authorize any person or company to create any Warranty obligations or liability on its behalf. This Warranty is not extended by the length of time which you are deprived of the use of the Dometic Product.
9. **IN NO EVENT SHALL SELLER BE LIABLE FOR EITHER INCIDENTAL OR CONSEQUENTIAL DAMAGES. THIS INCLUDES ANY DAMAGE TO ANOTHER PRODUCT OR PRODUCTS RESULTING FROM SUCH A DEFECT. SOME STATES DO NOT ALLOW THE EXCLUSION OR LIMITATION OF INCIDENTAL OR CONSEQUENTIAL DAMAGES, SO THE ABOVE LIMITATIONS MAY NOT APPLY TO YOU.**
10. **ANY IMPLIED WARRANTY, INCLUDING THE IMPLIED WARRANTY OF MERCHANTABILITY AND FITNESS FOR ANY PURPOSE, IS LIMITED TO THE DURATION OF THIS LIMITED WARRANTY. SOME STATES DO NOT ALLOW LIMITATIONS ON HOW LONG AN IMPLIED WARRANTY LASTS, SO THE ABOVE LIMITATION MAY NOT APPLY TO YOU.**
11. **THIS WARRANTY GIVES SPECIFIC LEGAL RIGHTS, YOU MAY ALSO HAVE OTHER RIGHTS WHICH VARY FROM STATE TO STATE.** No action to enforce this Warranty shall be commenced later than ninety (90) days after the expiration of the Warranty Period. Claims must be submitted in writing to the Dometic Warranty Department.
12. The Seller reserves the right to change the design of any Dometic product without notice and with no obligation to make corresponding changes in Dometic products previously manufactured.

PROTECTION FOR YOUR NEW INVESTMENT

We appreciate that you have chosen to purchase a Dometic product for your recreational vehicle and we want to help you protect this wise investment. We at Dometic, back our products with one of the most comprehensive warranties in the industry.

Register your product online at: www.edometic.com.

Dometic Corporation

Warranty Department
1120 North Main Street
Elkhart, Indiana 46514
1-574-294-2511

Register Your Product @
www.eDometic.com

REVISION A

Form No. 33403 (8/17)
(French 33404)

©2017 Dometic Corporation
LaGrange, IN 46761