

SET UP YOUR WALLY

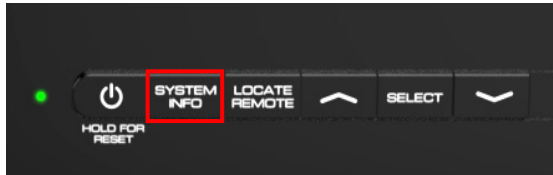

STEP 1: Unpair Your Remote

If you are unable to turn on your original receiver, go to step 2.



A Press the SYSTEM INFO button on the front panel of your original receiver.

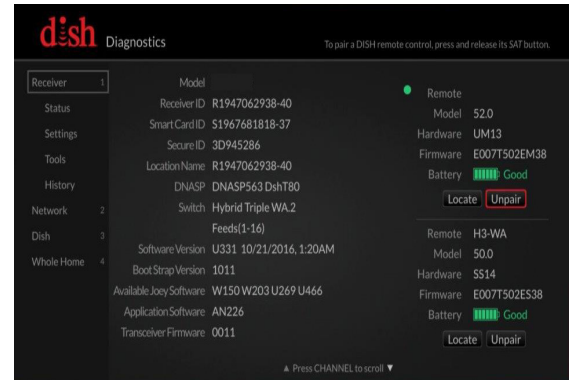

B Locate your remote from the list on the right-hand side of the screen. Then, use your remote control to highlight the “Unpair” option and press the SELECT button.

QUICK TIP



You will not be able to use your remote with your replacement receiver until you unpair it from your original receiver.

STEP 2: Label and Disconnect Your Cables

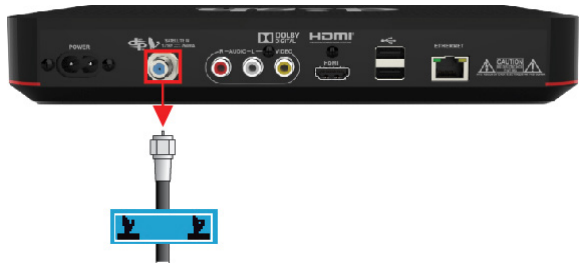

A Locate the cable connected to the “Satellite In” port and attach the blue label to it. Then, unscrew this cable from your Wally. Do not unscrew it from the wall.

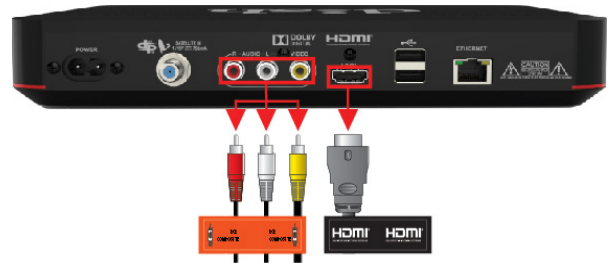

B Determine the cable you are using to receive audio/visual signal and attach the correct label to it. Then, unplug it from the receiver. Do not unplug it from your TV.

- **Orange label** - RCA cable
- **Black label** - HDMI cable

STEP 2: Label and Disconnect Your Cables (Cont.)



C Locate the cable connected to the “Ethernet” port, and attach the yellow label to it. Then, unplug it from the receiver. Do not disconnect it from the wall. **(You may not have this cable.)**



D Disconnect the power cord from the original receiver and the wall. A new power cord was shipped with your replacement Wally.

STEP 3: Connect the Cables to Your Replacement Receiver

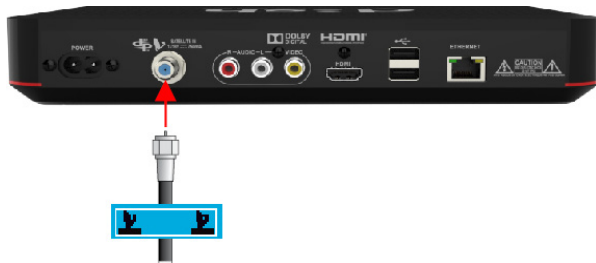

A Connect the Satellite In cable to the “Satellite In” port on your replacement Wally.

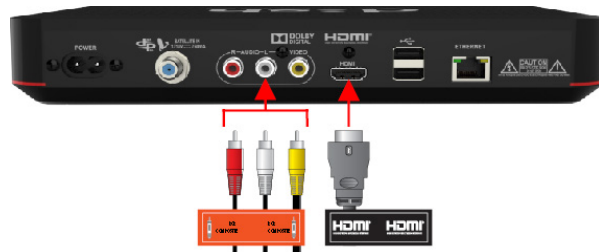

B Connect the RCA cables or the HDMI cable to the corresponding ports on your replacement Wally.

STEP 3: Connect the Cables (Cont.)



C Connect the Ethernet cable to the “Ethernet” port on your replacement Wally. **(You may not have this cable.)**



D Connect the power cord that came with your replacement Wally to the “Power” port on the new Wally.

STEP 4: Power Your Equipment

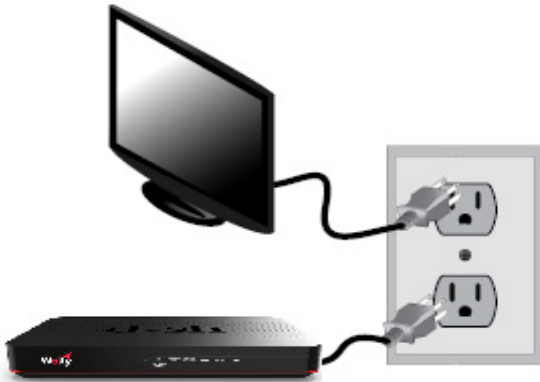

A Plug the power cord from your replacement Wally into a power outlet, and ensure that your TV is still plugged in. Turn your TV on.



B Make sure that the Smart Card is secured firmly in the slot on the side of your replacement Wally.

STEP 4: Power Your Equipment (Cont.)



C Turn on your TV and you will see a loading screen, which could last for several minutes.

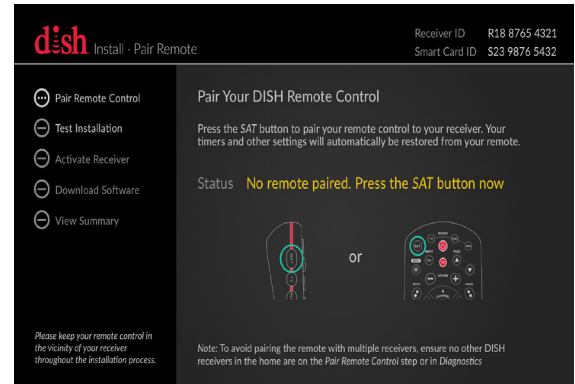

D When the Install Wizard screen appears, go to step 5.

QUICK TIP



If you do not see the loading screen, press the "Source/Input" button located on your TV until this screen appears.

STEP 5: Pair Your Remote to Your Wally

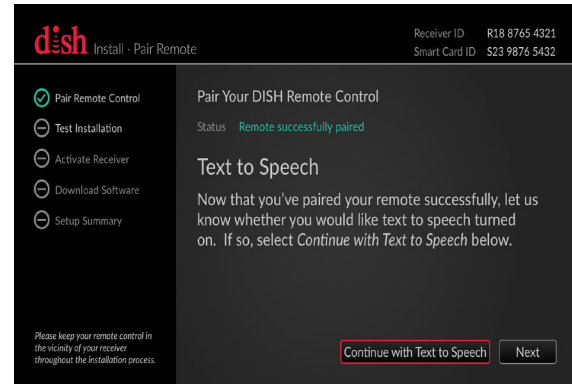
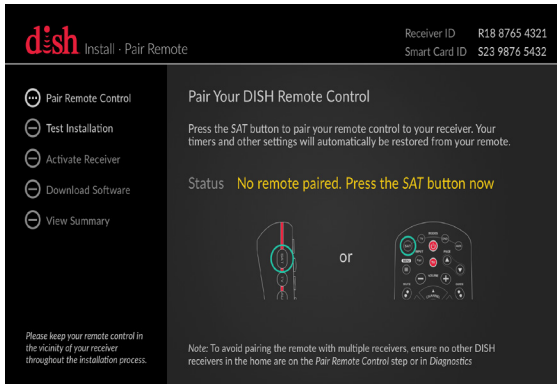

A Press the SAT button on your remote control to pair it to your Wally. All of your previous receiver's recording timers and other settings will be restored automatically.

B Once your remote is paired, the Install Wizard will proceed to the next step automatically.

QUICK TIP

To avoid pairing your remote with multiple receivers, ensure that you do not have any other receivers in your home that are on the "Pair Remote Control" step or in the "Diagnostics" screen.

STEP 6: Set Up Text to Speech

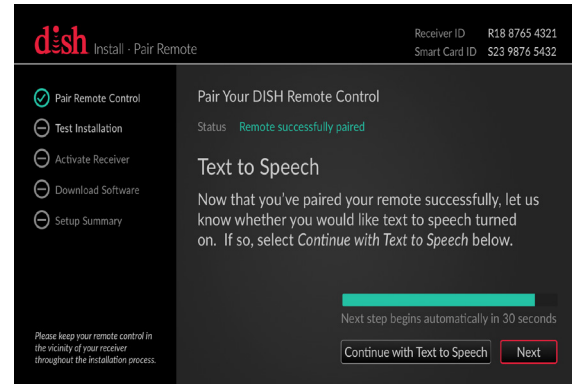
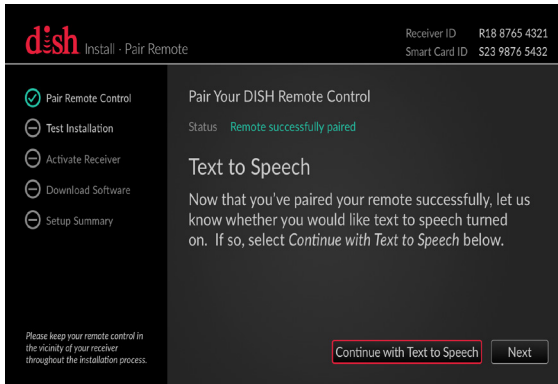

A If you would like to have a digital voice read the text on screen, use your remote control to highlight “Continue with Text to Speech.” Then, press SELECT.

B If you do not want a digital voice to read the text on screen, use your remote control to highlight “Next,” and press SELECT.

STEP 7: Set Your TV Resolution

Depending on the type of television you own, you may not see this screen.
If this screen does not appear, skip to step 8.

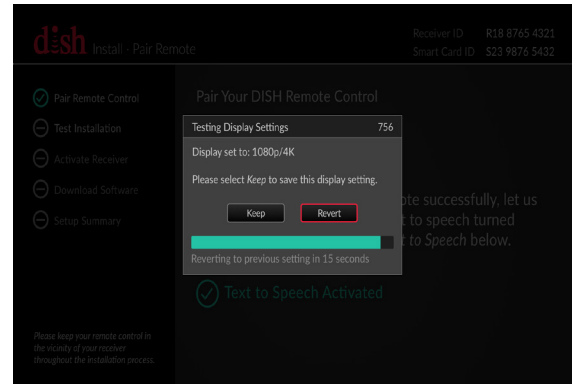
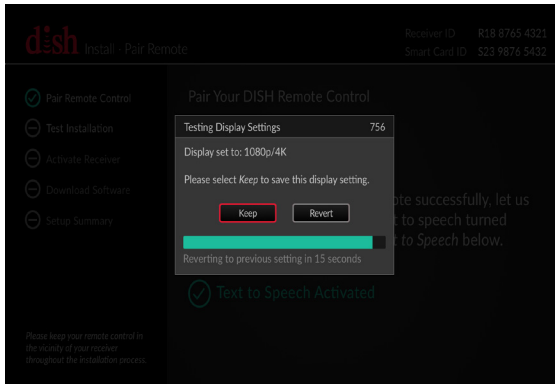

A If the image on the screen looks clear and correct, use your remote control to highlight the “Keep” option. Then, press SELECT.

B If the image on the screen looks incorrect, use your remote control to highlight “Revert.” Then, press SELECT.

QUICK TIP

If you do not select either option, the Install Wizard will automatically advance after 15 seconds.

STEP 8: Acquire Satellite Signal

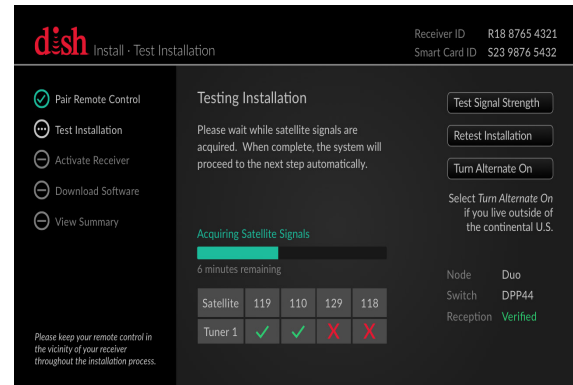
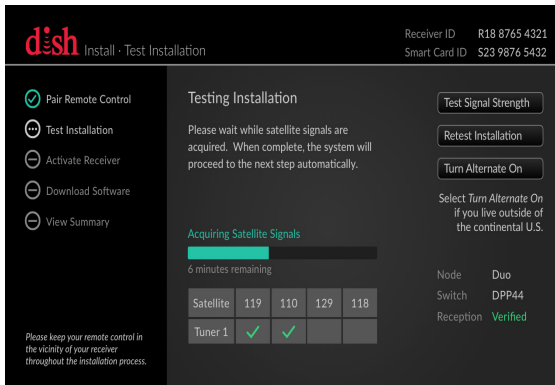

A Wait while your Wally acquires satellite signal. This could take up to 10 minutes. Once signal is acquired, the Install Wizard will proceed to the next step automatically.

B If red “X’s” appear in the installation summary, ensure that the “Home Video Network” cable is firmly connected to your Wally and the wall. Then, use your remote control to highlight “Retest Installation” and press SELECT.

STEP 9: Activate Your Wally (Internet Connection)

If your Wally is not connected to the Internet, skip to step 9E.

dish Install · Activate Receiver Call 1-800-333-DISH (3474) Receiver ID R18 8765 4321 for assistance Smart Card ID: S23 9876 5432

Pair Remote Control
Test Installation
Activate Receiver
Download Software
View Summary

Activate Your Receiver

Internet Connectivity **Connected**
Activation Status **Waiting for activation signal...**

Using the number pad on your remote, enter the zip code listed on your account and either your account number or the receiver ID from your previous receiver.

1. Zip Code

2. DISH Account Number
or
Previous Receiver ID R

Your previous receiver ID can be located on the back of your previous receiver.

Please keep your remote control in the vicinity of your receiver throughout the installation process.

dish Install · Activate Receiver Call 1-800-333-DISH (3474) Receiver ID R18 8765 4321 for assistance Smart Card ID: S23 9876 5432

Pair Remote Control
Test Installation
Activate Receiver
Download Software
View Summary

Activate Your Receiver

Internet Connectivity **Connected**
Activation Status **Waiting for activation signal...**

Using the number pad on your remote, enter the zip code listed on your account and either your account number or the receiver ID from your previous receiver.

1. Zip Code

2. DISH Account Number
or
Previous Receiver ID R

Your previous receiver ID can be located on the back of your previous receiver.

Please keep your remote control in the vicinity of your receiver throughout the installation process.

A Use your remote to highlight the “Zip Code” field and press SELECT. Then use the number pad on your remote control to enter your ZIP Code.

B Use your remote control to highlight either the “DISH Account Number” field, or the “Previous Receiver ID” field. Then, press SELECT and use the number pad to enter the selected number.

QUICK TIP

You can find your account number in the upper-right corner of your DISH bill, or in the My Account Summary section of your mydish.com account.

STEP 9: Activate Your Wally (Internet Connection Cont.)

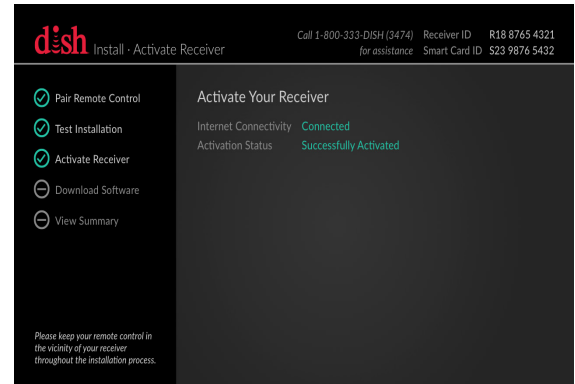
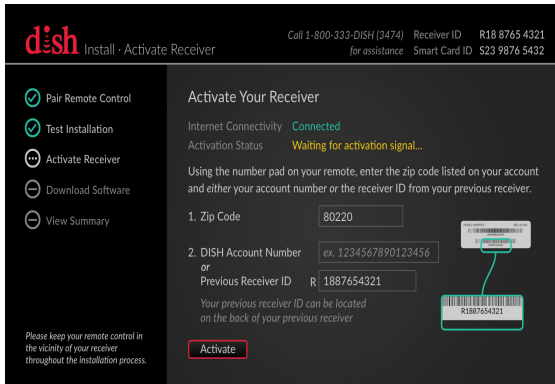

C Use your remote control to highlight the “Activate” button, and then press SELECT.

D Once activated, you will see a screen confirming that you activated your Joey successfully. The Install Wizard will then advance to the next screen automatically. Go to step 10.

STEP 9: Activate Your Wally (No Internet Connection)

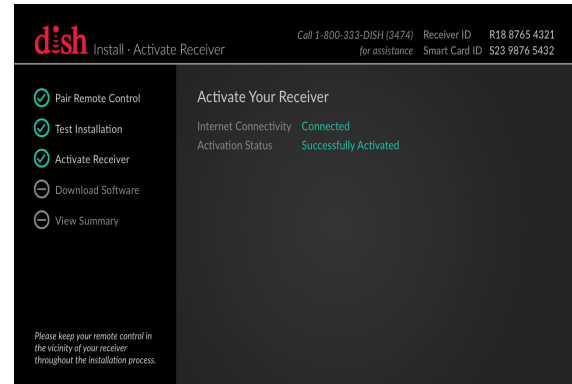
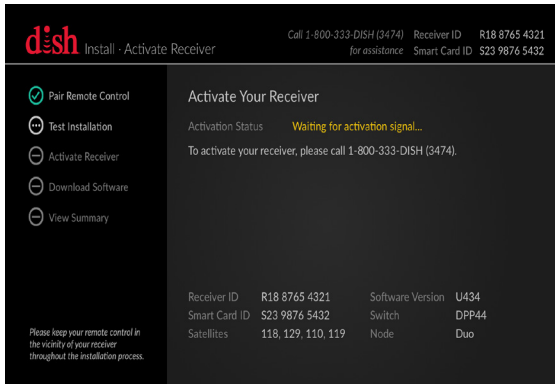

E If your Wally is not connected to the Internet, call 1-800-333-3474 (DISH) to activate it with a DISH agent. You will need the Receiver ID and Smart Card ID located on the Activation screen.

F Once activated, you will see a screen confirming that you activated your Joey successfully. The Install Wizard will then advance to the next screen automatically.

QUICK TIP

If you would like to connect to a wireless network, select the "Internet Settings" button, select "Wireless Setup," and follow the onscreen instructions.

STEP 10: Download Wally Software

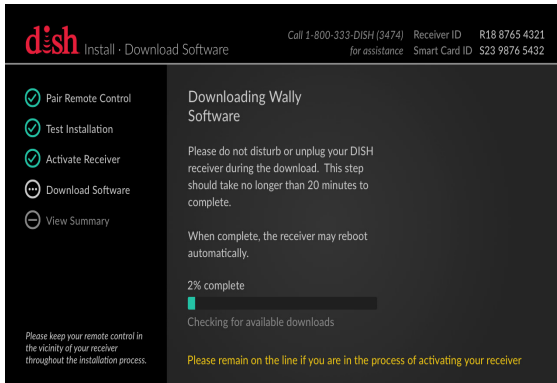

A Your Wally will start downloading software automatically. This process will take approximately 20 minutes.

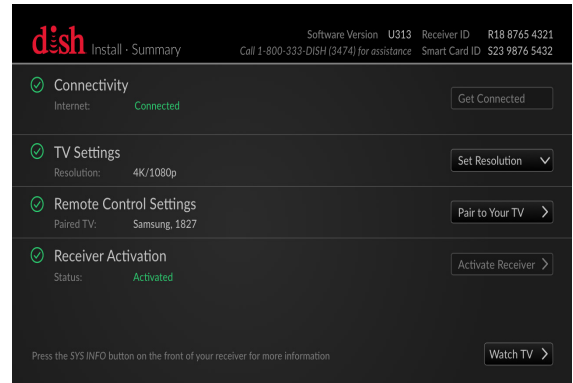

B Once your Wally completes the software download, the Install Wizard will advance to the Summary screen automatically.

STEP 12: Review the Summary Screen

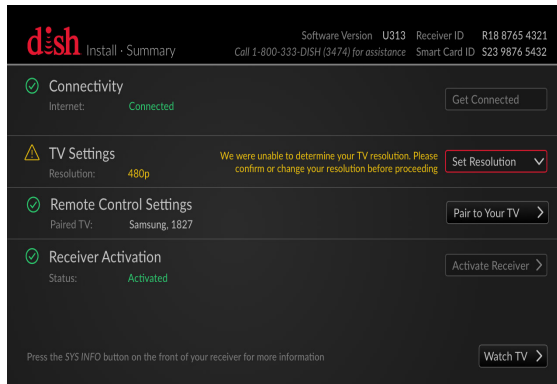

A Review the Summary screen. Any fields with green checkmarks are completed, and yellow fields are steps that need your attention. To change the information in a yellow field, highlight the dropdown tile and press SELECT. Then, select your desired option from the dropdown menu that appears.

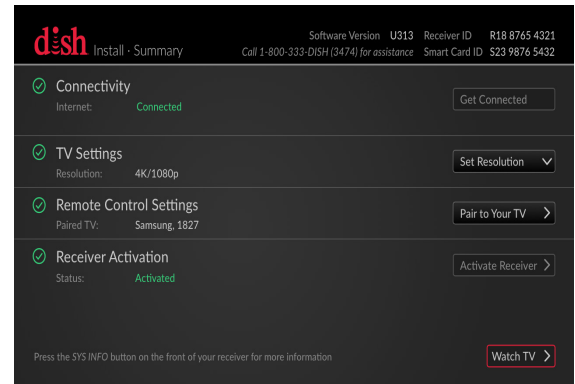

B When you have completed all of the steps on the Summary screen, select the “Watch TV” tile to start watching your favorite programming with DISH.

STEP 10: Return Your Original Receiver

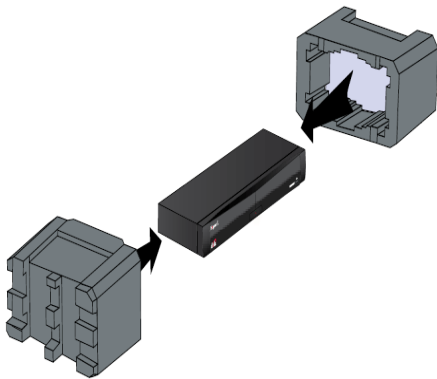

A Carefully wrap the power cord around the receiver, and then pack the receiver in between the foam protection.

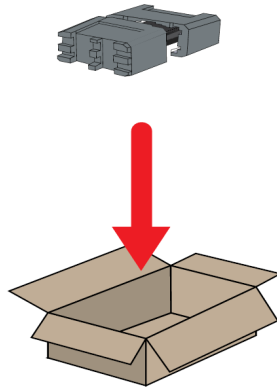

B Place the protected receiver in the box that the new receiver came in.

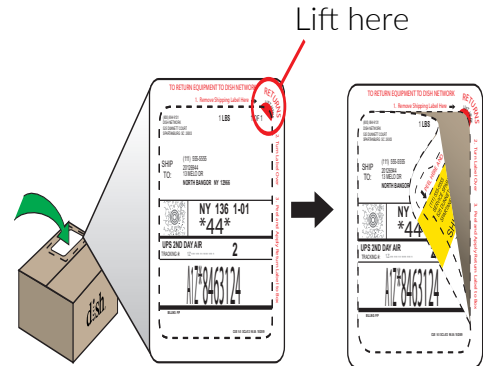

C Locate the original shipping label on the box and remove it using the red tab.

QUICK TIP



If there is a Smart Card in your receiver, do not remove it. A new Smart Card has been issued with your new receiver. Do not pack any other equipment or attachments.

STEP 10: Return Your Original Receiver (Cont.)

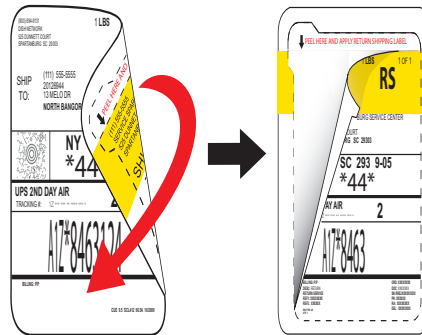
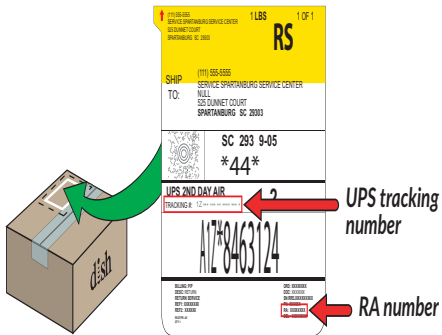

D Turn the original label over and peel off the yellow return shipping label to expose the adhesive.

E Copy the RA and UPS tracking numbers for your records, and apply the yellow return label to the top of the box and seal it.

F Return the original receiver at the nearest UPS dropoff location.

QUICK TIP 

To find the nearest UPS dropoff location, or to schedule a pickup at your cost, visit [ups.com/dropoff](https://www.ups.com/dropoff).

mydish

Want the convenience of managing your account anywhere at anytime?

Download the MyDISH app from the Apple App Store or Google Play Store to view and pay your bill, change your programming, and do more on your mobile device.

Customer Support

- mydish.com/chat
- 1-800-333-DISH [3474]
- mydish.com/support

Channel 103

Hopper Insider is a fantastic show, where DISH experts walk you through the billing process, troubleshooting, equipment features, and more!

Help App

Access helpful information about your equipment by pressing and holding Info/Help on your remote.

dish